

UTL®

Konik Kilit Sistemleri / Locking Assemblies

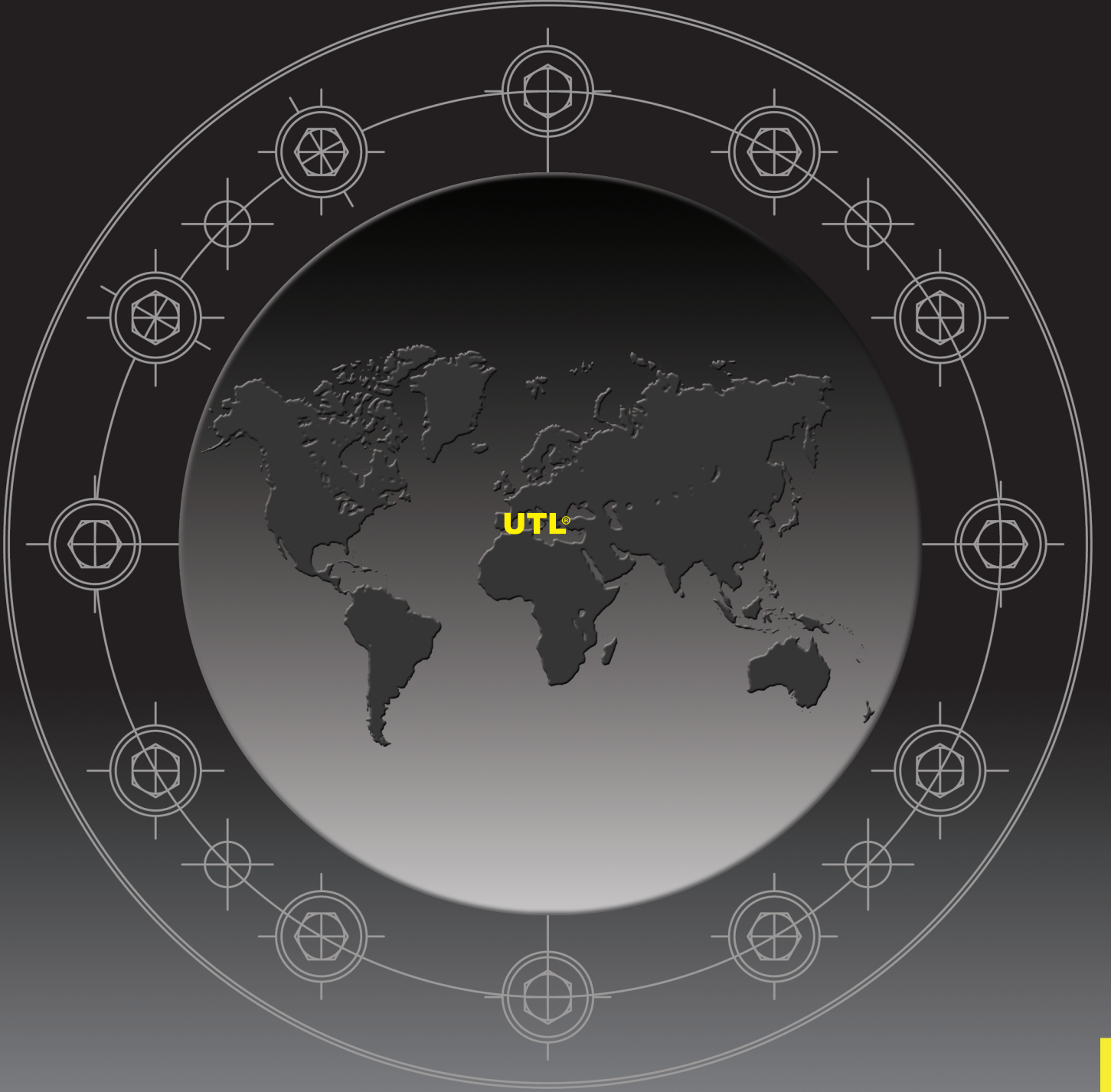

UTL®

**tecrübe & kalite
experience & quality**



UTL Konik Kilit Sistemleri bir Şahsan Torna markasıdır. Şahsan Torna bu katalogda belirtilen tüm

bilgileri deęiřtirme hakkını saklı tutar.

Bu katalogdaki bilgilerin bir kısmı veya tamamı UTL markası belirtilmeden kopyalanamaz.

Şahsan Torna reserves the right to modify all data indicated in this catalogue. This catalogue may not be reproduced, either wholly or partly without the written authorisation of Şahsan Torna.

ŞAHSAN

www.utl.com.tr

www.utllockingassemblies.com

İçindekiler / Table Of Contents

Standart Seri Konik Kilitler / Standard Series Locking Assemblies	6-27
Mini Seri / Mini Series	28-37
UTL Plus / UTL Plus	38-55
Paslanmaz Konik Kilitler / Locking Assemblies Stainless Steel	56-67
Kilitleme Elemanları / Locking Elements	68-69
Şirink Diskler / Shrink Discs	70-77
Rijit Kaplinler / Rigid Couplings	78-81
Karşılaştırma Rehberi / Interchange Guide	84

UTL® Konik Kilitleme Sistemleri



Çeşitli aktarma elemanlarının poyralarını (kasnaklar, makaralar, dişliler, silindirler vb.) millere bağlanmasında kama gerektirmeden sabitlenmesini sağlayan çok üstün ve arzulanılan hedefe ulaştıran bir sistemdir.

UTL® Konik Kilitleme Sistemlerinin avantajları

- ✓ Son derece güvenli uyum, boşluksuz, aşındırmaz mükemmel sabitleme,
- ✓ Kusursuz büyük dönme momenti ve eksensel kuvvet aktarımı
- ✓ Zaman ve işçilikten kazanım, makine yapım ve bakım maliyetlerinde azalma
- ✓ Uygulama, bakım ve onarım kolaylığı
- ✓ İleri ve geri hareketlerde çok güvenli, darbelere dayanıklı ve uzun ömürlü
- ✓ Kullanım alanı çok geniş ve de sorunsuz
- ✓ Aşırı yük bindirmelerinde kaydırma yaparak sistemin kırılmasını, bozulmasını önleme.
- ✓ Mil üstünde ve göbek deliğinde kama açma gibi işlemlerin ortadan kalkması, makine işlem sayısında indirgeme.
- ✓ Mil üzerinde istenen konumda hassas sabitleme.
- ✓ Takma ve sökme işlemi gayet basit ve hızlı yapılırken sistemin zarar görmemesi.
- ✓ Her yerde bulunabilecek normal aletlerin kullanılabilmesi.
- ✓ Çektirme sistemi sayesinde kolayca çıkarılabilmesi.

UTL® Konik Kilit Sistemlerinin uygulanması

- ✓ Milin ve poyranın sürtünen yüzeylerini temizleyin ve ince yağla bir tabaka oluşturun. Molibden bisülfat ve gres yağı kullanmayınız.
- ✓ Kilitleme sistemini milin üzerinden kaydırarak poyranın içine doğru yerleştirin.
- ✓ Cıvatalarıyla her iki parçayı önerilen tork Mt(Nm) elde edilene kadar yavaş yavaş düzenli bir şekilde ardışık olarak veya çapraz olarak sıkıştırın.
- ✓ Sıkma işlemlerinde tork anahtarı kullanılması önerilir.
- ✓ Sıcaklık sınırları : - 40 ve +300°C

UTL® Locking Assemblies



It is a very superior system which reaches the desired target which ensures fixing without any need of wedge in connecting hubs of various power transmission to shaft (hubs, spools, gears, cylinders, etc.).

Advantages of the UTL® Locking Assemblies

- ✓ Perfect fixing without cavity and abrasion, which ensures considerable reliability
- ✓ Perfect great rotation momentum and axial power transfer
- ✓ Gain in time and workmanship, decrease in the machine production and maintenance costs
- ✓ Application, maintenance and reparation convenience
- ✓ Very reliable in the forward and reverse movements, resistant to the strokes and long lasting
- ✓ With wide and problem-free usage area
- ✓ Prevention of the system breakage and spoiling by means of making shift on the excessive load overlaps.
- ✓ Eliminating the processes such as wedge opening on shaft and in the hub hole, and reduction in the machine process number.
- ✓ Sensitive fixing on the required position on the shaft.
- ✓ While performing the attachment and disassembly process very easily and rapidly, not damaging the system.
- ✓ Using the normal tools which could be found everywhere.
- ✓ Easy removal by pull out screw threads.

Application of the UTL® Locking Assemblies

- ✓ Clean the surfaces on which the shaft and hub rub and form a layer with thin oil. Do not use molybdenum bisulphate and grease oil.
- ✓ Shift the locking system on shaft and place into hub.
- ✓ Tighten both of the parts with shaft fixing screws gradually, in diagonal sequence up to torque Mt(Nm)
- ✓ Using torque wrench is recommended in the tightening processes.
- ✓ Temperature limits: - 40 and +300°C

UTL® Konik Kilitleme Sistemleri



Türkiye makine üreticisinin diğer ülkelerin makine üreticileri ile Dünya makine pazarında rekabet edebilmeleri ancak aynı kaliteyi yakalamalarıyla mümkün olacaktır. Bu yüzden teknolojiyi yakından takip eden seçkin makine üreticileri, mühendisleri ve teknisyenleri yanında birçok seçkin sanayi kuruluşu makinelerini elden geçirerek eski sistemleri terk edip UTL Konik Kilit Sistemini kullanmaya başlamışlardır.

Makine üretiminde güç aktarma organlarının (dişli, kasnak, kaplin, vollar) sabitlenmesi çok önem taşımaktadır. Sanayisi gelişmiş ülkelerde geleneksel sabitleme sistemlerinin (gömme kama, teğetsel kama, çakma kama vb.) kullanılması terk edilmiş, yerine çok daha başarılı ve üstünlüğü herkes tarafından kabul görmüş konik kilitleme sistemleri kullanılmaya başlanmıştır. Önceki yıllarda ancak Çin den ithal edilen bu sistemler 2010 yılından itibaren ülkemizde de UTL Konik Kilit olarak Alman ve İtalyan normlarına dolayısıyla Dünya standartlarına uygun olarak üretilmektedir.

Türkiye piyasalarında bu konik kilit sistemlerin adlandırılmasında (konik kilit, sıkma bilezik, tiperlok, sıkma burç, ayarlı kasnak, powerlock, kilitle pens) bir karmaşa yaşansa da makine üreticileri, mühendisler ve teknisyenlerin işini çok kolaylaştırdığı için UTL Konik Kilit vazgeçilmez bir ürün olmuştur.

UTL Konik Kilit sistemi, birbiri içine geçmiş iki konik bileziğin üzerlerindeki civataların sıkılması ile birbirlerini ters yönlere iterek içlerinden geçen mili ve dışlarından geçen göbeği birbirine kuvvetli bir şekilde sabitlemesidir.

Kamalı sistem imalatı ucuz olmasının yanında birçok zayıf noktası bulunmaktadır. Bu yüzden birçok makine üreticisi kamalı sistemi kullanmayı bırakmıştır.

UTL Konik Kilit Sisteminin de ise standartlara göre üretim yapıldığından mil ve göbek üzerinde fazladan işlem yapılmadan yerine kolayca takılması ; boşluksuz çalışması ; eksensel kuvvet taşıyabilmesi ; sökme kolaylığı ; kama yuvası bulunan millere de uygulanabilir olması ; tork kapasitesinin ısıdan etkilenmemesi ; yüksek radyal kuvvet taşıyabilmesi ; aşırı yükler geldiğinde yerinden oynayarak hem kendisini hem de sistemi koruması gibi birçok üstün özelliklere sahiptir.

2010 yılı başından itibaren Türkiye'de Şahsan Torna tarafından UTL markasıyla konik kilit ailesinin tüm çeşitleri Dünya standartlarına uygun kalitede üretilerek bu ileri teknoloji ürünleri sanayimizin hizmetine sunulmuştur.

UTL® Locking Assemblies



To compete of Turkish machine manufacturer with machine manufacturers in other countries in the World Machine Market is only possible to catch the same quality. So besides many distinguish machine manufacturers, engineers and technicians and many distinguish industry enterprises that closely follow the technology revise their machines; quit their old systems and begin to use UTL Locking Assemblies.

It is very important to fix power transmission (gear, hub, coupling, and flywheel) at the machine manufacturing. Traditional fixing methods (sunk key, tangential key, pile key...etc) using has been quitted in the countries of which industry have been developed, instead of it Conic Key systems of which success and superiority has been approved by everybody became used. Those products are only can be import from China in the previous years but since 2010 this system has began to manufactured in our country as UTL Locking Assemblies in German and Italy standards so in the world standards.

Although a complexity has been lived to call this key system in Turkish Market (konik kilit, sıkma bilezik, tiperlok, sıkma burç, ayarlı kasnak, powerlock, kilitle pens) UTL Locking Assemblies has been an indispensable product for the machine manufacturers, engineers and technicians due to making easy their job.

UTL Locking Assemblies is tightening the screws on two conic bracelets that are interlocked and fixing strongly the pin that passes insides of them and center that passes outside of them through pushing each other to opposite sides.

Besides being cheap of keyed system, it has many weak points. So many machine manufacturers quit to use keyed system.

At UTL Locking Assemblies, it has been manufactured according to standards so it has so many superior features as; easy assembling to its place without applying so much process on pin and center; operating without space; ability to carry axial force; easy disassembling; applicability to pins that have keyway; not being effective of torque capacity from heat; to be ability to carry high radial force; when over load is applied it moves from its place so it keeps both itself and the system.

Since beginning of 2010, all kinds of locking assemblies family has been manufactured under UTL mark in accordance with world standards by Şahsan Torna in Turkey and this advance technology products have been presented to service of our industry.

UTL®

Standart Seri Konik Kilitler Standard Series Locking Assemblies

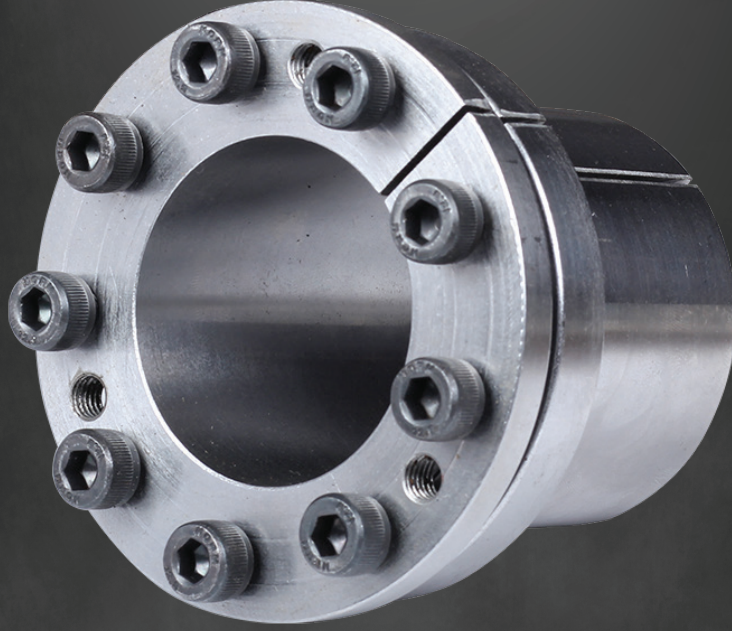

UTL - 100



KENDİLİĞİNDEN YATAKLAYAN

UTL - 100 ; iki konik parça, bir çember ve DIN 912 normlarına uygun bağlantı elemanlarından oluşmaktadır.

Orta ve yüksek tork gerektiren yerlerde ve küçük çaplı uygulamalarda önerilir.

H8-h8 Tolerans - $R_t \leq 16 \mu\text{m}$

SELF-CENTERING

Locking assembly with single taper design. Consists of two tapered rings and a spacer. It has minimum overall dimensions in virtue of the reduced thickness of the cones. UTL-100 is suitable for the applications where small hubs are requested. It is recommended for mid-high torques and is self centering.

H8-h8 Tolerance - $R_t \leq 16 \mu\text{m}$

www.utl.com.tr

www.utllockingassemblies.com

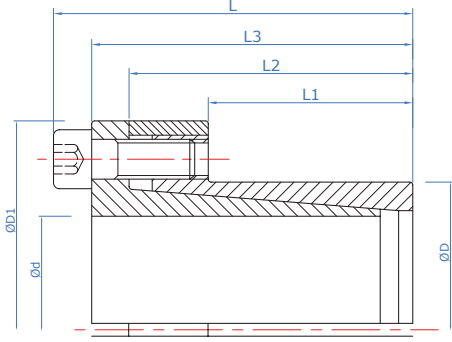

UTL - 100 Teknik Özellikler / Technical Properties

Ma	Vida sıkma döndürme momenti / Screw tightening torque
Mt	Maksimum aktarılabilen döndürme momenti (Fass=0 kN) / Transmissible torque moment
Fass	Maksimum aktarılabilen eksenel yük (Mt=0 Nm) / Transmissible axial load
Ps	Mile temas basıncı / Shaft pressure
Ph	Göbek çapına temas basıncı / Hub pressure

Sipariş Kodu / Code	Ölçüler / Dimensions							Bağlantı elemanları / Tightening screws		Başarımlar / Performances					Ağırlık / Weight kg
	d	D	L1	L2	L3	L	D1	DIN 912		Ma	Mt	Fass	Ps	Ph	
	mm	mm	mm	mm	mm	mm	mm	Ad.	12.9 TİP	Nm	Nm	kN	N/mm ²	N/mm ²	
UTL 100 - 6	6	14	10	18,5	21	24	25	3	M3	2	12	4	185	80	0,04
UTL 100 - 7	7	15	12	22	25	29	27	3	M4	5	25	7	235	110	0,06
UTL 100 - 8	8	15	12	22	25	29	27	3	M4	5	29	7	205	110	0,05
UTL 100 - 9	9	16	14	23	26	30	28	4	M4	5	44	10	205	115	0,06
UTL 100 - 10	10	16	14	23	26	30	28	4	M4	5	49	10	185	115	0,06
UTL 100 - 11	11	18	14	23	26	30	32	4	M4	5	53	10	170	105	0,07
UTL 100 - 12	12	18	14	23	26	30	32	4	M4	5	58	10	160	105	0,07
UTL 100 - 13	13	23	14	23	26	30	38	4	M4	5	63	10	140	80	0,11
UTL 100 - 14	14	23	14	23	26	30	38	4	M4	5	68	10	130	80	0,1
UTL 100 - 15	15	24	16	29	36	42	45	3	M6	17	127	17	185	115	0,22
UTL 100 - 16	16	24	16	29	36	42	45	3	M6	17	136	17	175	115	0,22
UTL 100 - 17	17	26	18	31	38	44	47	4	M6	17	180	22	190	125	0,25
UTL 100 - 18	18	26	18	31	38	44	47	4	M6	17	200	22	180	125	0,24
UTL 100 - 19	19	27	18	31	38	44	49	4	M6	17	210	22	170	120	0,26
UTL 100 - 20	20	28	18	31	38	44	50	4	M6	17	220	22	160	115	0,27
UTL 100 - 22	22	32	25	38	45	51	54	4	M6	17	250	22	115	80	0,34
UTL 100 - 24	24	34	25	38	45	51	56	4	M6	17	270	22	105	75	0,36
UTL 100 - 25	25	34	25	38	45	51	56	4	M6	17	280	22	100	75	0,35
UTL 100 - 28	28	39	25	38	45	51	61	6	M6	17	465	33	135	97	0,48
UTL 100 - 30	30	41	25	38	45	51	62	6	M6	17	510	33	127	90	0,48
UTL 100 - 32	32	43	25	38	45	51	65	6	M6	17	540	33	120	90	0,47
UTL 100 - 35	35	47	32	45	52	58	69	6	M6	17	790	45	105	80	0,58
UTL 100 - 38	38	50	32	45	52	58	72	8	M6	17	860	45	100	75	0,61
UTL 100 - 40	40	53	32	45	52	58	75	8	M6	17	900	45	95	70	0,68
UTL 100 - 42	42	55	35	45	52	58	78	8	M6	17	950	45	90	70	0,76
UTL 100 - 45	45	59	45	62	70	78	86	8	M8	41	1.890	84	110	85	1,2
UTL 100 - 48	48	62	45	62	70	78	87	8	M8	41	2.010	84	105	80	1,2
UTL 100 - 50	50	65	45	62	70	78	92	8	M8	41	2.100	84	100	75	1,4
UTL 100 - 55	55	71	55	72	80	88	98	9	M8	41	2.600	94	85	65	1,6
UTL 100 - 60	60	77	55	72	80	88	104	9	M8	41	2.840	94	75	60	1,8
UTL 100 - 65	65	84	55	72	80	88	111	9	M8	41	3.070	94	70	55	2,1
UTL 100 - 70	70	90	65	86	96	106	119	9	M10	83	5.250	150	90	70	3
UTL 100 - 75	75	95	65	86	96	106	126	9	M10	83	5.600	150	80	65	3,0
UTL 100 - 80	80	100	65	86	96	106	131	12	M10	83	8.020	200	100	80	3,5
UTL 100 - 85	85	106	65	86	96	106	137	12	M10	83	8.500	200	95	75	3,6
UTL 100 - 90	90	112	65	86	96	106	144	12	M10	83	9.000	200	90	75	3,9
UTL 100 - 95	95	120	65	86	96	106	149	14	M10	83	11.000	230	100	80	4,4
UTL 100 - 100	100	125	65	86	96	106	154	18	M10	83	15.000	300	120	95	4,6
UTL 100 - 110	110	140	90	114	128	140	180	12	M12	145	16.000	290	80	65	8,7
UTL 100 - 120	120	155	90	114	128	140	198	12	M12	145	17.500	290	70	55	10,6
UTL 100 - 130	130	165	90	114	128	140	208	16	M12	145	25.000	384	90	70	11,3

UTL®

Standart Seri Konik Kilitler Standard Series Locking Assemblies



UTL - 200



KENDİLİĞİNDEN YATAKLAMAYAN

UTL - 200 ; dış ve iç çember, iki konik yanak ve DIN 912 normlarına uygun bağlantı elemanlarından oluşmaktadır.

Orta ve yüksek tork gerektiren yerlerde, çok amaçlı olarak uygulanması önerilir.

H8-h8 Tolerans - $R_t \leq 16 \mu\text{m}$



NOT SELF-CENTERING

UTL - 200 locking assembly unit consists of four pieces with two inside double-cone rings joined through a set of tightening screws.

It is recommended for medium torques. Although it is not self centering, it can be easily assembled and disassembled.

H8-h8 Tolerance - $R_t \leq 16 \mu\text{m}$

www.utl.com.tr

www.utllockingassemblies.com

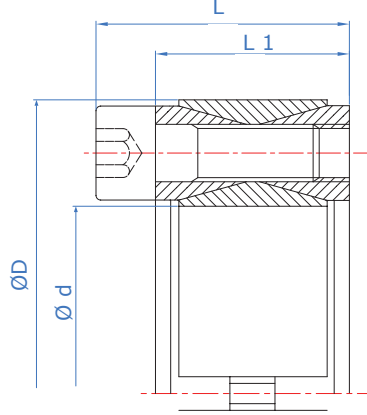

UTL - 200 Teknik Özellikler / Technical Properties

Ma	Vida sıkma döndürme momenti / Screw tightening torque
Mt	Maksimum aktarılabilen döndürme momenti (Fass=0 kN) / Transmissible torque moment
Fass	Maksimum aktarılabilen eksenel yük (Mt=0 Nm) / Transmissible axial load
Ps	Mile temas basıncı / Shaft pressure
Ph	Göbek çapına temas basıncı / Hub pressure

Sipariş Kodu / Code	Ölçüler / Dimensions				Bağlantı elemanları / Tightening screws		Başarımlar / Performances					Ağırlık / Weight kg
	d	D	L1	L	DIN 912		Ma	Mt	Fass	Ps	Ph	
	mm	mm	mm	mm	Ad.	12.9 TİP	Nm	Nm	kN	N/mm ²	N/mm ²	
UTL 200 - 18	18	47	20	27	8	M6	15	260	29	225	95	0,2
UTL 200 - 19	19	47	20	27	8	M6	15	270	29	225	95	0,2
UTL 200 - 20	20	47	20	27	8	M6	15	280	29	225	95	0,3
UTL 200 - 22	22	47	20	27	8	M6	15	310	29	210	95	0,3
UTL 200 - 24	24	50	20	27	8	M6	15	370	32	210	100	0,3
UTL 200 - 25	25	50	20	27	8	M6	15	400	32	200	100	0,3
UTL 200 - 28	28	55	20	27	10	M6	15	500	36	200	100	0,3
UTL 200 - 30	30	55	20	27	10	M6	15	530	36	185	100	0,3
UTL 200 - 32	32	60	20	27	12	M6	15	680	42	205	110	0,3
UTL 200 - 35	35	60	20	27	12	M6	15	750	43	190	110	0,3
UTL 200 - 38	38	65	20	27	14	M6	15	930	49	200	115	0,4
UTL 200 - 40	40	65	20	27	14	M6	15	980	49	190	115	0,3
UTL 200 - 42	42	75	24	33	12	M8	37	1.580	75	235	130	0,6
UTL 200 - 45	45	75	24	33	12	M8	37	1.700	76	220	130	0,6
UTL 200 - 48	48	80	24	33	12	M8	37	1.790	74	210	120	0,6
UTL 200 - 50	50	80	24	33	12	M8	37	1.870	75	200	120	0,6
UTL 200 - 55	55	85	24	33	14	M8	37	2.390	88	210	135	0,6
UTL 200 - 60	60	90	24	33	14	M8	37	2.610	88	190	125	0,7
UTL 200 - 65	65	95	24	33	16	M8	37	3.210	98	200	135	0,7
UTL 200 - 70	70	110	28	39	14	M10	70	4.600	132	210	130	1,3
UTL 200 - 75	75	115	28	39	14	M10	70	4.900	131	195	125	1,3
UTL 200 - 80	80	120	28	39	14	M10	70	5.200	131	180	120	1,4
UTL 200 - 85	85	125	28	39	16	M10	70	6.300	148	195	130	1,4
UTL 200 - 90	90	130	28	39	16	M10	70	6.600	147	180	125	1,5
UTL 200 - 95	95	135	28	39	18	M10	70	7.900	167	195	135	1,6
UTL 200 - 100	100	145	33	47	14	M12	127	9.750	195	195	135	2,2
UTL 200 - 110	110	155	33	47	14	M12	127	10.650	194	180	125	2,5
UTL 200 - 120	120	165	33	47	16	M12	127	13.300	221	185	135	2,6
UTL 200 - 130	130	180	38	52	20	M12	127	17.850	276	165	115	3,8
UTL 200 - 140	140	190	38	52	22	M12	127	21.200	302	165	125	3,9
UTL 200 - 150	150	200	38	52	24	M12	127	24.500	329	170	125	4,0
UTL 200 - 160	160	210	38	52	26	M12	127	28.400	355	170	130	4,3
UTL 200 - 170	170	225	44	60	22	M14	195	33.600	396	165	120	5,8
UTL 200 - 180	180	235	44	60	24	M14	230	38.700	431	170	130	6,0
UTL 200 - 190	190	250	52	68	28	M14	230	44.700	502	155	120	8,5
UTL 200 - 200	200	260	52	68	30	M14	230	53.500	538	155	120	8,6
UTL 200 - 220	220	285	56	74	26	M16	300	68.500	630	155	120	11
UTL 200 - 240	240	305	56	74	30	M16	300	86.000	717	165	130	12
UTL 200 - 260	260	325	56	74	34	M16	300	105.000	810	165	135	13
UTL 200 - 280	280	355	66	86	32	M18	410	128.500	920	150	120	19
UTL 200 - 300	300	375	66	86	36	M18	410	153.600	1.025	155	125	20

Daha büyük çaplı UTL Konik Kilit ihtiyaçlarınız için bizi arayınız. / For assemblies requiring larger dimensions, contact our technical department.

UTL®

Standart Seri Konik Kilitler Standard Series Locking Assemblies



UTL - 201



KENDİLİĞİNDEN YATAKLAYAN

UTL - 201 ; İki konik parça ve DIN 912 normlarına uygun bağlantı elemanlarından oluşmaktadır.

Düşük ve orta tork gerektiren yerlerde uygulanması önerilir.

H8 - h8 Tolerans - $Rt \leq 16\mu m$

SELF-CENTERING

UTL - 201 ; Two conical parts and conforming to DIN 912 norms consists of connectors.

It is recommended to be applied in places that require low and medium torque.

H8 - h8 Tolerance - $Rt \leq 16\mu m$

www.utl.com.tr

www.utllockingassemblies.com

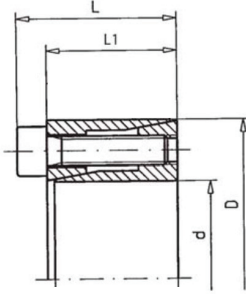

UTL - 201 Teknik Özellikler / Technical Properties

Ma	Vida sıkma döndürme momenti / Screw tightening torque
Mt	Maksimum aktarılabilen döndürme momenti (Fass=0 kN) / Transmissible torque moment
Fass	Maksimum aktarılabilen aksel yük (Mt=0 Nm) / Transmissible axial load
Ps	Mile temas basıncı / Shaft pressure
Ph	Göbek çapına temas basıncı / Hub pressure

Sipariş Kodu / Code	Ölçüler / Dimensions				Bağlantı elemanları / Tightening screws		Başarımlar / Performances					Ağırlık / Weight kg
	d	D	L1	L	DIN 912		Ma	Mt	Fass	Ps	Ph	
	mm	mm	mm	mm	Adet	12,9 TİP	Nm	Nm	kN	N/mm ²	N/mm ²	
UTL 201 - 20	20	47	29	35	4	M6	17	280	2S	154	65	0,3
UTL 201 - 22	22	47	29	35	4	M6	17	310	2S	140	65	0,3
UTL 201 - 24	24	50	29	35	4	M6	17	400	33	154	74	0,3
UTL 201 - 25	25	50	29	35	4	M6	17	420	33	14S	74	0,3
UTL 201 - 2S	2S	55	29	35	6	M6	17	470	33	132	67	0,4
UTL 201 - 30	30	55	29	35	6	M6	17	500	33	123	67	0,3
UTL 201 - 32	32	55	29	35	6	M6	17	710	45	154	S2	0,4
UTL 201 - 35	35	60	31	37	8	M6	17	780	45	141	S2	0,4
UTL 201 - 3S	3S	65	31	37	8	M6	17	850	45	130	76	0,4
UTL 201 - 40	40	65	31	37	8	M6	17	890	45	123	76	0,4
UTL 201 - 42	42	75	36	44	6	M8	41	1.500	720	152	S5	0,7
UTL 201 - 45	45	75	36	44	6	M8	41	1600	720	142	S5	0,7
UTL 201 - 4S	4S	80	36	44	8	M8	41	1700	720	133	80	0,8
UTL 201 - 50	50	80	36	44	8	M8	41	1.800	720	127	80	0,8
UTL 201 - 55	55	S5	36	44	8	M8	41	2.300	S2	132	S6	0,8
UTL 201 - 60	60	90	36	44	8	M8	41	2.500	S2	121	S1	0,9
UTL 201 - 65	65	95	36	44	9	M8	41	3.000	93	126	S6	0,9
UTL 201 - 70	70	110	4S	5S	8	M10	S3	4700	135	12S	S1	1,8
UTL 201 - 75	75	115	4S	58	8	M10	83	5.100	135	119	78	1,9
UTL 201 - 80	80	120	48	58	8	M10	83	5.400	135	112	75	2
UTL 201 - 85	85	125	48	58	9	M10	83	6.500	152	119	81	2,1
UTL 201 - 90	90	130	48	58	9	M10	83	6.800	152	112	78	2,2
UTL 201 - 95	95	135	48	58	10	M10	83	8.000	169	118	83	2,3
UTL 201 - 100	100	145	56	68	8	M12	145	10.100	202	107	74	34
UTL 201 - 110	110	155	56	68	8	M12	145	11.100	202,0	97	69	37
UTL 201 - 120	120	165	56	68	9	M12	145	13.600	227,0	100	73	4
UTL 201 - 130	130	180	68	80	10	M12	145	19.700	303,0	101	73	5,9

UTL®

Standart Seri Konik Kilitler Standard Series Locking Assemblies

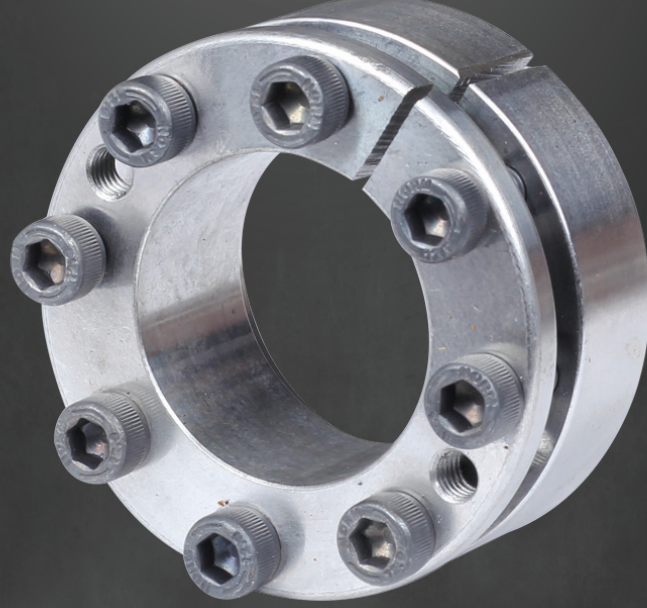

UTL - 300



KENDİLİĞİNDEN YATAKLAYAN

UTL - 300 ; iki konik parça ve DIN 912 normlarına uygun bağlantı elemanlarından oluşmaktadır.

Orta tork gerektiren yerlerde uygulanması önerilir.

H8-h8 Tolerans - $R_t \leq 16 \mu m$

SELF-CENTERING

Locking assembly with single taper design. Provides good concentricity and is self centering. A small axial movement of the hub during the installation operation may occur. Applications requiring accurate axial positioning are not recommended with this type of locking assembly. UTL-300 is suitable for applications with medium torques.

H8-h8 Tolerance - $R_t \leq 16 \mu m$

www.utl.com.tr

www.utllockingassemblies.com

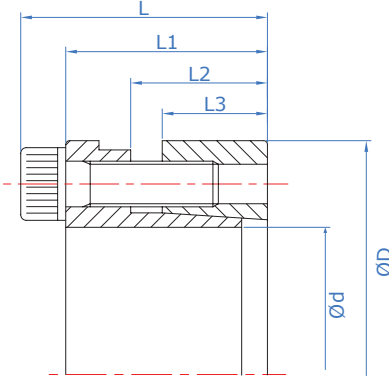

UTL - 300 Teknik Özellikler / Technical Properties

Ma	Vida sıkma döndürme momenti / Screw tightening torque
Mt	Maksimum aktarılabilen döndürme momenti (Fass=0 kN) / Transmissible torque moment
Fass	Maksimum aktarılabilen eksenel yük (Mt=0 Nm) / Transmissible axial load
Ps	Mile temas basıncı / Shaft pressure
Ph	Göbek çapına temas basıncı / Hub pressure

Sipariş Kodu / Code	Ölçüler / Dimensions						Bağlantı elemanları / Tightening screws		Başarımlar / Performances					Ağırlık / Weight kg
	d	D	L3	L2	L1	L	DIN 912		Ma	Mt	Fass	Ps	Ph	
	mm	mm	mm	mm	mm	mm	Ad.	12.9 TİP	Nm	Nm	kN	N/mm ²	N/mm ²	
UTL 300 - 20	20	47	17	22	28	34	5	M6	14	380	38	295	125	0,3
UTL 300 - 22	22	47	17	22	28	34	5	M6	14	410	38	270	125	0,3
UTL 300 - 24	24	50	17	22	28	34	6	M6	14	450	38	245	120	0,3
UTL 300 - 25	25	50	17	22	28	34	6	M6	14	570	46	285	140	0,3
UTL 300 - 28	28	55	17	22	28	34	6	M6	14	630	46	255	130	0,4
UTL 300 - 30	30	55	17	22	28	34	6	M6	14	660	46	235	130	0,3
UTL 300 - 32	32	60	17	22	28	34	8	M6	14	970	60	295	155	0,4
UTL 300 - 35	35	60	17	22	28	34	8	M6	14	1.060	60	270	155	0,4
UTL 300 - 38	38	65	17	22	28	34	8	M6	14	1.150	60	250	145	0,4
UTL 300 - 40	40	65	17	22	28	34	8	M6	14	1.210	60	235	145	0,4
UTL 300 - 42	42	75	20	25	33	41	7	M8	35	2.050	98	300	170	0,8
UTL 300 - 45	45	75	20	25	33	41	7	M8	35	2.200	98	290	170	0,6
UTL 300 - 48	48	80	20	25	33	41	7	M8	35	2.350	98	270	160	0,8
UTL 300 - 50	50	80	20	25	33	41	7	M8	35	2.450	98	260	160	0,8
UTL 300 - 55	55	85	20	25	33	41	8	M8	35	3.080	112	270	175	0,8
UTL 300 - 60	60	90	20	25	33	41	8	M8	35	3.360	112	245	165	0,8
UTL 300 - 65	65	95	20	25	33	41	9	M8	35	4.090	126	255	175	0,9
UTL 300 - 70	70	110	24	30	40	50	8	M10	70	6.300	179	280	180	1,8
UTL 300 - 75	75	115	24	30	40	50	8	M10	70	6.700	179	260	170	1,8
UTL 300 - 80	80	120	24	30	40	50	8	M10	70	7.150	179	250	170	1,8
UTL 300 - 85	85	125	24	30	40	50	9	M10	70	8.500	200	260	180	2,0
UTL 300 - 90	90	130	24	30	40	50	9	M10	70	9.100	200	250	170	2,1
UTL 300 - 95	95	135	24	30	40	50	10	M10	70	10.600	224	260	180	2,1
UTL 300 - 100	100	145	26	32	44	56	8	M12	125	13.400	268	270	190	2,8
UTL 300 - 110	110	155	26	32	44	56	8	M12	125	14.600	268	240	180	3
UTL 300 - 120	120	165	26	32	44	56	9	M12	125	17.900	298	250	180	3,2
UTL 300 - 130	130	180	34	40	54	66	12	M12	125	26.000	400	240	170	4,8
UTL 300 - 140	140	190	34	40	54	68	9	M14	190	27.000	384	210	150	5,2
UTL 300 - 150	150	200	34	40	54	68	10	M14	190	33.000	440	230	170	5,4
UTL 300 - 160	160	210	34	40	54	68	11	M14	190	38.000	479	230	170	5,7
UTL 300 - 170	170	225	44	50	64	78	12	M14	190	45.000	530	180	130	8
UTL 300 - 180	180	235	44	50	64	78	12	M14	190	47.000	530	170	130	8,3
UTL 300 - 190	190	250	44	50	64	78	15	M14	190	62.900	660	170	115	9,6
UTL 300 - 200	200	260	44	50	64	78	15	M14	190	73.700	625	160	130	10
UTL 300 - 220	220	285	50	56	75	91	12	M16	295	63.700	579	140	120	13,4
UTL 300 - 240	240	305	50	56	75	91	15	M16	295	87.000	725	160	110	14,3
UTL 300 - 260	260	325	50	56	75	91	18	M16	295	113.000	869	180	125	15,5
UTL 300 - 280	280	355	60	66	87	105	16	M18	405	131.500	930	150	140	22
UTL 300 - 300	300	375	60	66	87	105	18	M18	405	158.500	1.060	155	120	24,4
UTL 300 - 320	320	405	74	81	104	124	18	M20	580	218.000	1.363	155	125	36,1
UTL 300 - 340	340	425	74	81	104	124	21	M20	580	270.000	1.588	170	135	38,4
UTL 300 - 360	360	455	86	94	120	142	18	M22	780	305.000	1.694	145	115	46,2

Daha büyük çaplı UTL Konik Kilit ihtiyaçlarınız için bizi arayınız. / For assemblies requiring larger dimensions, contact our technical department.

UTL®

Standart Seri Konik Kilitler Standard Series Locking Assemblies

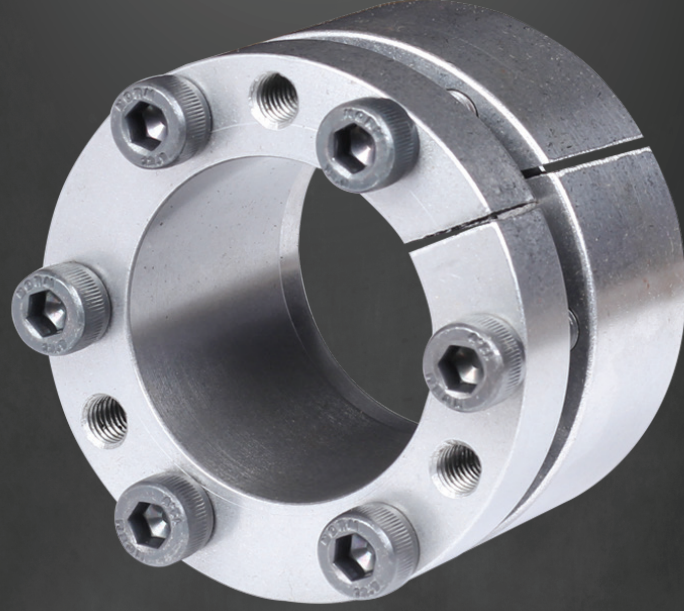

UTL - 301



KENDİLİĞİNDEN YATAKLAYAN

UTL - 301 ; iki konik parça ve DIN 912 normlarına uygun bağlantı elemanlarından oluşmaktadır.

Yüksek tork gerektiren yerlerde uygulanması önerilir.

H8-h8 Tolerans - $R_t \leq 16 \mu\text{m}$

SELF-CENTERING

Locking assembly with single taper design. It is suitable for high torques. Provide good concentricity and self centering. A small axial movement of the hub during the installation operation may occur.

Applications in need of an accurate axial positioning are not recommended with this type of locking assembly.

H8-h8 Tolerance - $R_t \leq 16 \mu\text{m}$

www.utl.com.tr

www.utllockingassemblies.com

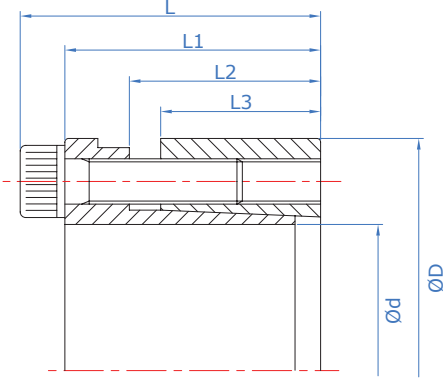

UTL - 301 Teknik Özellikler / Technical Properties

Ma	Vida sıkma döndürme momenti / Screw tightening torque
Mt	Maksimum aktarılabilen döndürme momenti (Fass=0 kN) / Transmissible torque moment
Fass	Maksimum aktarılabilen eksenel yük (Mt=0 Nm) / Transmissible axial load
Ps	Mile temas basıncı / Shaft pressure
Ph	Göbek çapına temas basıncı / Hub pressure

Sipariş Kodu / Code	Ölçüler / Dimensions						Bağlantı elemanları / Tightening screws		Başarımlar / Performances					Ağırlık / Weight kg
	d	D	L3	L2	L1	L	DIN 912		Ma	Mt	Fass	Ps	Ph	
	mm	mm	mm	mm	mm	mm	Ad.	12.9 TİP	Nm	Nm	kN	N/mm ²	N/mm ²	
UTL 301 - 20	20	47	26	30	41	47	6	M6	17	540	54	280	120	0,4
UTL 301 - 22	22	47	26	30	41	47	6	M6	17	600	54	255	120	0,4
UTL 301 - 24	24	50	26	30	41	47	6	M6	17	650	54	235	115	0,4
UTL 301 - 25	25	50	26	30	41	47	6	M6	17	680	54	225	115	0,4
UTL 301 - 28	28	55	26	30	41	47	6	M6	17	760	54	200	105	0,5
UTL 301 - 30	30	55	26	30	41	47	6	M6	17	820	54	185	105	0,5
UTL 301 - 32	32	60	26	30	41	47	8	M6	17	1.160	73	235	125	0,6
UTL 301 - 35	35	60	26	30	41	47	8	M6	17	1.270	73	215	125	0,5
UTL 301 - 38	38	65	26	30	41	47	8	M6	17	1.380	73	200	115	0,6
UTL 301 - 40	40	65	26	30	41	47	8	M6	17	1.450	73	190	115	0,6
UTL 301 - 42	42	75	30	35	49	57	6	M8	41	2.130	101	215	120	1
UTL 301 - 45	45	75	30	35	49	57	6	M8	41	2.280	101	200	120	1
UTL 301 - 48	48	80	30	35	49	57	6	M8	41	2.430	101	190	115	1,1
UTL 301 - 50	50	80	30	35	49	57	6	M8	41	2.530	101	180	115	1
UTL 301 - 55	55	85	30	35	49	57	8	M8	41	3.700	135	220	140	1,1
UTL 301 - 60	60	90	30	35	49	57	8	M8	41	4.000	135	200	135	1,2
UTL 301 - 65	65	95	30	35	49	57	8	M8	41	4.380	135	185	125	1,3
UTL 301 - 70	70	110	40	45	59	69	8	M10	83	7.500	214	205	130	2,2
UTL 301 - 75	75	115	40	45	59	69	8	M10	83	8.000	214	190	125	2,5
UTL 301 - 80	80	120	40	45	59	69	8	M10	83	8.560	214	180	120	2,6
UTL 301 - 85	85	125	40	45	59	69	10	M10	83	11.370	268	210	145	2,8
UTL 301 - 90	90	130	40	45	59	69	10	M10	83	12.000	268	200	135	2,7
UTL 301 - 95	95	135	40	45	59	69	10	M10	83	12.600	268	190	130	2,9
UTL 301 - 100	100	145	46	52	68	80	8	M12	145	15.580	312	180	125	3,9
UTL 301 - 110	110	155	46	52	68	80	8	M12	145	17.100	312	165	115	4,2
UTL 301 - 120	120	165	46	52	68	80	10	M12	145	23.370	390	190	135	4,8
UTL 301 - 130	130	180	46	52	68	80	12	M12	145	30.380	467	210	150	5
UTL 301 - 140	140	190	50	57	76	90	8	M14	230	29.900	428	165	120	6,5
UTL 301 - 150	150	200	50	57	76	90	10	M14	230	40.000	535	190	145	7
UTL 301 - 160	160	210	50	57	76	90	10	M14	230	42.750	535	180	135	7
UTL 301 - 170	170	225	50	57	76	90	12	M14	230	54.500	641	200	150	8,5
UTL 301 - 180	180	235	50	57	76	90	12	M14	230	57.700	641	190	145	9
UTL 301 - 190	190	250	50	57	76	90	16	M14	230	72.000	750	230	165	10,57
UTL 301 - 200	200	260	50	57	76	90	16	M14	230	76.000	750	210	165	11,24
UTL 301 - 220	220	285	64	72	98	102	12	M16	355	65.400	655	254	195	14,8
UTL 301 - 240	240	305	64	72	98	102	16	M16	355	107.000	888	267	210	15,7
UTL 301 - 260	260	325	64	72	98	102	18	M16	355	130.000	1.001	279	223	17
UTL 301 - 280	280	355	75	83	121	127	16	M18	485	158.000	1.128	245	193	36
UTL 301 - 300	300	375	75	83	121	127	18	M18	485	190.000	1.264	257	206	37
UTL 301 - 320	320	405	90	98	140	148	18	M20	690	260.000	1.627	259	205	38,5
UTL 301 - 340	340	425	90	98	140	148	22	M20	690	275.000	1.620	244	195	40,4
UTL 301 - 360	360	455	110	118	164	174	18	M22	930	356.000	1.980	242	192	56,7

Daha büyük çaplı UTL Konik Kilit ihtiyaçlarınız için bizi arayınız. / For assemblies requiring larger dimensions, contact our technical department.

UTL®

Standart Seri Konik Kilitler Standard Series Locking Assemblies

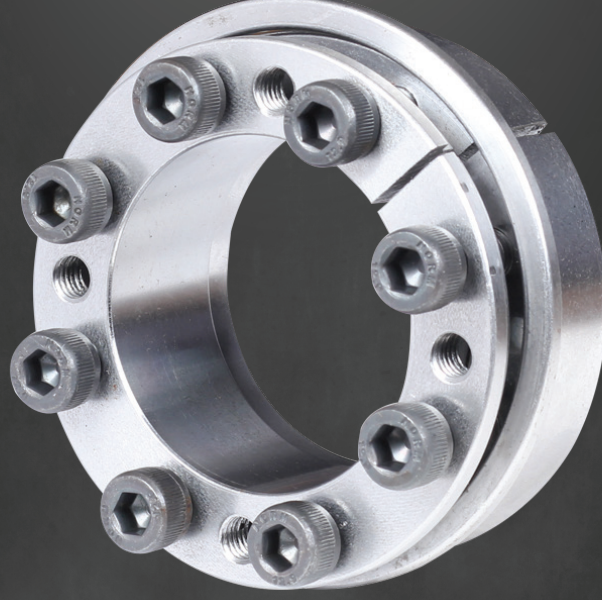

UTL - 350



KENDİLİĞİNDEN YATAKLAYAN

UTL - 350 ; iki konik parça, bir aksenal kaymayı önleyici bilezik ve DIN 912 normlarına uygun bağlantı elemanlarından oluşmaktadır.

Orta tork gerektiren yerlerde uygulanması önerilir.

H8-h8 Tolerans - $R_t \leq 16 \mu m$

SELF-CENTERING

Locking assembly with single taper design.

Provide good concentricity and self centering. It is recommended for medium torques and is self-centering. The flange design prevent axial movement during installation.

H8-h8 Tolerance - $R_t \leq 16 \mu m$

www.utl.com.tr

www.utllockingassemblies.com

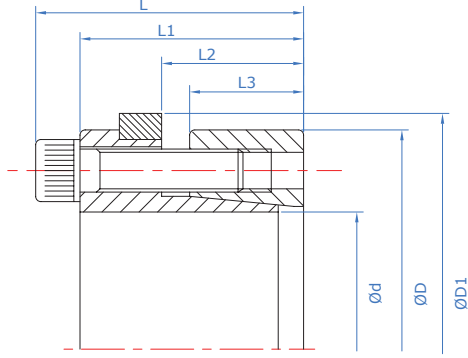

UTL - 350 Teknik Özellikler / Technical Properties

Ma	Vida sıkma döndürme momenti / Screw tightening torque
Mt	Maksimum aktarılabilen döndürme momenti (Fass=0 kN) / Transmissible torque moment
Fass	Maksimum aktarılabilen aksel yük (Mt=0 Nm) / Transmissible axial load
Ps	Mile temas basıncı / Shaft pressure
Ph	Göbek çapına temas basıncı / Hub pressure

Sipariş Kodu / Code	Ölçüler / Dimensions							Bağlantı elemanları / Tightening screws		Başarımlar / Performances					Ağırlık / Weight kg
	d	D	D1	L3	L2	L1	L	DIN 912		Ma	Mt	Fass	Ps	Ph	
	mm	mm	mm	mm	mm	mm	mm	Ad.	12.9 TİP	Nm	Nm	kN	N/mm ²	N/mm ²	
UTL 350 - 20	20	47	54	17	22	28	34	5	M6	17	380	38	295	125	0,3
UTL 350 - 22	22	47	54	17	22	28	34	5	M6	17	410	38	270	125	0,3
UTL 350 - 24	24	50	57	17	22	28	34	6	M6	17	450	46	245	120	0,3
UTL 350 - 25	25	50	57	17	22	28	34	6	M6	17	570	46	285	140	0,3
UTL 350 - 28	28	55	62	17	22	28	34	6	M6	17	630	46	255	130	0,4
UTL 350 - 30	30	55	62	17	22	28	34	6	M6	17	660	46	235	130	0,3
UTL 350 - 32	32	60	67	17	22	28	34	8	M6	17	970	60	295	155	0,4
UTL 350 - 35	35	60	67	17	22	28	34	8	M6	17	1.060	60	270	155	0,4
UTL 350 - 38	38	65	72	17	22	28	34	8	M6	17	1.150	60	250	145	0,4
UTL 350 - 40	40	65	72	17	22	28	34	8	M6	17	1.210	60	235	145	0,4
UTL 350 - 42	42	75	82	20	25	33	41	7	M8	41	2.050	98	300	170	0,8
UTL 350 - 45	45	75	82	20	25	33	41	7	M8	41	2.200	98	290	170	0,6
UTL 350 - 48	48	80	87	20	25	33	41	7	M8	41	2.350	98	270	160	0,8
UTL 350 - 50	50	80	87	20	25	33	41	7	M8	41	2.450	98	260	160	0,8
UTL 350 - 55	55	85	92	20	25	33	41	8	M8	41	3.080	112	270	175	0,8
UTL 350 - 60	60	90	97	20	25	33	41	8	M8	41	3.360	112	245	165	0,8
UTL 350 - 65	65	95	102	20	25	33	41	9	M8	41	4.090	126	255	175	0,9
UTL 350 - 70	70	110	117	24	30	40	50	8	M10	83	6.300	179	280	180	1,8
UTL 350 - 75	75	115	122	24	30	40	50	8	M10	83	6.700	179	260	170	1,8
UTL 350 - 80	80	120	127	24	30	40	50	8	M10	83	7.150	179	250	170	1,8
UTL 350 - 85	85	125	132	24	30	40	50	9	M10	83	8.500	200	260	180	2,0
UTL 350 - 90	90	130	137	24	30	40	50	9	M10	83	9.100	200	250	170	2,1
UTL 350 - 95	95	135	142	24	30	40	50	10	M10	83	10.600	224	260	180	2,1
UTL 350 - 100	100	145	152	26	32	44	56	8	M12	145	13.400	268	270	190	2,8
UTL 350 - 110	110	155	162	26	32	44	56	8	M12	145	14.600	268	240	180	3
UTL 350 - 120	120	165	172	26	32	44	56	9	M12	145	17.900	298	250	180	3,2
UTL 350 - 130	130	180	187	34	40	54	66	9	M14	230	26.000	400	240	170	4,8
UTL 350 - 140	140	190	197	34	40	54	68	9	M14	230	27.000	384	210	150	5,2
UTL 350 - 150	150	200	207	34	40	54	68	10	M14	230	33.000	440	230	170	5,4
UTL 350 - 160	160	210	217	34	40	54	68	11	M14	230	38.000	479	230	170	5,7
UTL 350 - 170	170	225	232	44	50	64	78	12	M14	230	45.000	530	180	130	8
UTL 350 - 180	180	235	242	44	50	64	78	12	M14	230	47.000	530	170	130	8,3
UTL 350 - 190	190	250	257	44	50	64	78	15	M14	230	62.900	660	210	150	9,6
UTL 350 - 200	200	260	267	44	50	64	78	15	M14	230	66.000	660	190	150	10,7
UTL 350 - 220	220	285	292	50	56	73	89	12	M16	355	80.970	736	178	137	14,4
UTL 350 - 240	240	305	312	50	56	73	89	15	M16	355	110.420	920	203	160	15,5
UTL 350 - 260	260	325	332	50	56	73	89	18	M16	355	143.550	1.104	225	180	16,7
UTL 350 - 280	280	355	362	60	66	85	103	16	M18	485	166.210	1.187	187	148	24
UTL 350 - 300	300	375	382	60	66	85	103	18	M18	485	200.340	1.335	197	157	26,5
UTL 350 - 320	320	405	412	74	81	102	122	18	M20	690	279.320	1.745	196	155	38
UTL 350 - 340	340	425	432	74	81	102	122	21	M20	690	346.240	2.036	215	172	40

Daha büyük çaplı UTL Konik Kilit ihtiyaçlarınız için bizi arayınız. / For assemblies requiring larger dimensions, contact our technical department.

UTL®

Standart Seri Konik Kilitler Standard Series Locking Assemblies



UTL - 350F



KENDİLİĞİNDEN YATAKLAYAN

UTL - 350F ; iki konik parça, bir aksenal kaymayı önleyici sabit flanş ve DIN 912 normlarına uygun bağlantı elemanlarından oluşmaktadır.

Orta tork gerektiren yerlerde uygulanması önerilir.

H8-h8 Tolerans - $R_t \leq 16 \mu m$

SELF-CENTERING

Locking assembly with single taper design. Provides good concentricity and self centering. It is recommended for medium torques and is self-centering.

The flange design prevents axial movement during installation.

H8-h8 Tolerance - $R_t \leq 16 \mu m$

www.utl.com.tr

www.utllockingassemblies.com

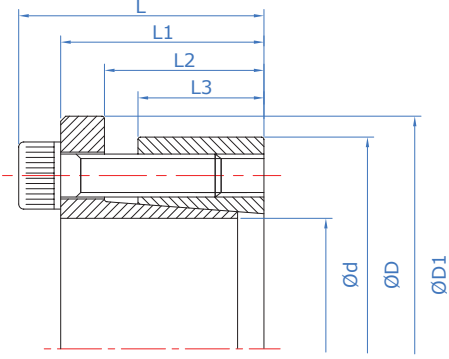

UTL - 350F Teknik Özellikler / Technical Properties

Ma	Vida sıkma döndürme momenti / Screw tightening torque
Mt	Maksimum aktarılabilen döndürme momenti (Fass=0 kN) / Transmissible torque moment
Fass	Maksimum aktarılabilen eksenel yük (Mt=0 Nm) / Transmissible axial load
Ps	Mile temas basıncı / Shaft pressure
Ph	Göbek çapına temas basıncı / Hub pressure

Sipariş Kodu / Code	Ölçüler / Dimensions							Bağlantı elemanları / Tightening screws		Başarımlar / Performances					Ağırlık / Weight kg
	d	D	D1	L3	L2	L1	L	DIN 912		Ma	Mt	Fass	Ps	Ph	
	mm	mm	mm	mm	mm	mm	mm	Ad.	12.9 TİP	Nm	Nm	kN	N/mm ²	N/mm ²	
UTL 350F - 20	20	47	54	17	22	28	34	5	M6	17	280	28	220	95	0,3
UTL 350F - 22	22	47	54	17	22	28	34	5	M6	17	300	28	200	95	0,3
UTL 350F - 24	24	50	57	17	22	28	34	6	M6	17	330	28	180	90	0,3
UTL 350F - 25	25	50	57	17	22	28	34	6	M6	17	420	34	210	105	0,3
UTL 350F - 28	28	55	62	17	22	28	34	6	M6	17	470	34	190	95	0,4
UTL 350F - 30	30	55	62	17	22	28	34	6	M6	17	500	34	175	95	0,4
UTL 350F - 32	32	60	67	17	22	28	34	8	M6	17	720	45	220	115	0,4
UTL 350F - 35	35	60	67	17	22	28	34	8	M6	17	790	45	200	115	0,4
UTL 350F - 38	38	65	72	17	22	28	34	8	M6	17	850	45	185	105	0,5
UTL 350F - 40	40	65	72	17	22	28	34	8	M6	17	900	45	175	105	0,5
UTL 350F - 42	42	75	82	20	25	33	41	7	M8	41	1.530	73	225	125	0,8
UTL 350F - 45	45	75	82	20	25	33	41	7	M8	41	1.650	73	215	125	0,7
UTL 350F - 48	48	80	87	20	25	33	41	7	M8	41	1.760	73	200	120	0,8
UTL 350F - 50	50	80	87	20	25	33	41	7	M8	41	1.830	73	195	120	0,8
UTL 350F - 55	55	85	92	20	25	33	41	8	M8	41	2.300	83	200	130	0,9
UTL 350F - 60	60	90	97	20	25	33	41	8	M8	41	2.510	83	185	125	0,9
UTL 350F - 65	65	95	102	20	25	33	41	9	M8	41	3.060	94	190	130	1
UTL 350F - 70	70	110	117	24	30	40	50	8	M10	83	4.670	133	210	135	1,9
UTL 350F - 75	75	115	122	24	30	40	50	8	M10	83	5.000	133	195	125	2
UTL 350F - 80	80	120	127	24	30	40	50	8	M10	83	5.300	133	185	125	2
UTL 350F - 85	85	125	132	24	30	40	50	9	M10	83	6.300	148	195	135	2
UTL 350F - 90	90	130	137	24	30	40	50	9	M10	83	6.750	148	185	130	2,2
UTL 350F - 95	95	135	142	24	30	40	50	10	M10	83	7.900	166	195	135	2,3
UTL 350F - 100	100	145	152	26	32	44	56	8	M12	145	9.700	194	200	140	3
UTL 350F - 110	110	155	162	26	32	44	56	8	M12	145	10.600	194	180	130	3,2
UTL 350F - 120	120	165	172	26	32	44	56	9	M12	145	13.000	216	185	135	3,4
UTL 350F - 130	130	180	187	34	40	54	68	9	M14	230	18.900	290	175	125	5,2
UTL 350F - 140	140	190	197	34	40	54	68	9	M14	230	20.500	290	165	120	5,4
UTL 350F - 150	150	200	207	34	40	54	68	10	M14	230	25.000	333	175	130	5,7
UTL 350F - 160	160	210	217	34	40	54	68	11	M14	230	29.000	362	180	135	6
UTL 350F - 170	170	225	232	44	50	64	78	12	M14	230	34.000	400	140	105	8,3
UTL 350F - 180	180	235	242	44	50	64	78	12	M14	230	36.000	400	135	105	8,8
UTL 350F - 190	190	250	257	44	50	64	78	15	M14	230	47.500	500	160	120	10
UTL 350F - 200	200	260	267	44	50	64	78	15	M14	230	50.000	500	150	115	10,5
UTL 350F - 220	220	285	292	50	56	73	89	12	M16	295	61.300	558	134	118	14,4
UTL 350F - 240	240	305	312	50	56	73	89	15	M16	295	83.600	697	154	104	15,5
UTL 350F - 260	260	325	332	50	56	73	89	18	M16	295	108.700	836	171	121	16,7
UTL 350F - 280	280	355	362	60	66	85	103	16	M18	405	125.600	897	142	137	24
UTL 350F - 300	300	375	382	60	66	85	103	18	M18	405	151.400	1.009	149	112	26,5
UTL 350F - 320	320	405	412	74	81	102	122	18	M20	580	209.200	1.308	146	119	38
UTL 350F - 340	340	425	432	74	81	102	122	21	M20	580	259.400	1.526	161	116	40
UTL 350F - 360	360	455	462	86	94	116	138	18	M22	780	291.600	1.620	139	129	48

Daha büyük çaplı UTL Konik Kilit ihtiyaçlarınız için bizi arayınız. / For assemblies requiring larger dimensions, contact our technical department.

UTL®

Standart Seri Konik Kilitler Standard Series Locking Assemblies



UTL - 351



KENDİLİĞİNDEN YATAKLAYAN

UTL - 351 ; iki konik parça, bir aksenal kaymayı önleyici bilezik ve DIN 912 normlarına uygun bağlantı elemanlarından oluşmaktadır.

Yüksek tork gerektiren yerlerde uygulanması önerilir.

H8-h8 Tolerans - $Rt \leq 16 \mu m$

SELF-CENTERING

Locking assembly with single taper design.

Provide good concentricity and self centering. It is recommended for high torques and is self-centering. The flange design prevent axial movement during installation.

H8-h8 Tolerance - $Rt \leq 16 \mu m$

www.utl.com.tr

www.utllockingassemblies.com

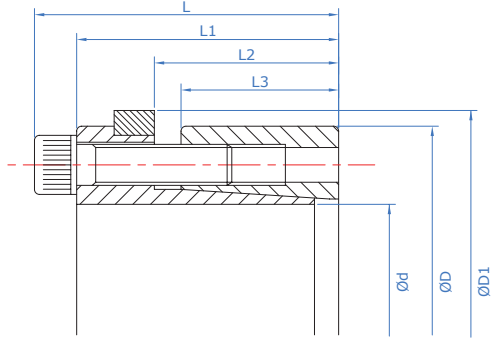

UTL - 351 Teknik Özellikler / Technical Properties

Ma	Vida sıkma döndürme momenti / Screw tightening torque
Mt	Maksimum aktarılabilen döndürme momenti (Fass=0 kN) / Transmissible torque moment
Fass	Maksimum aktarılabilen eksenel yük (Mt=0 Nm) / Transmissible axial load
Ps	Mile temas basıncı / Shaft pressure
Ph	Göbek çapına temas basıncı / Hub pressure

Sipariş Kodu / Code	Ölçüler / Dimensions							Bağlantı elemanları / Tightening screws		Başarımlar / Performances					Ağırlık / Weight kg
	d	D	D1	L3	L2	L1	L	DIN 912		Ma	Mt	Fass	Ps	Ph	
	mm	mm	mm	mm	mm	mm	mm	Ad.	12.9 TİP	Nm	Nm	kN	N/mm ²	N/mm ²	
UTL 351 - 20	20	47	53	26	30	42	48	6	M6	17	350	35	178	76	0,4
UTL 351 - 22	22	47	53	26	30	42	48	6	M6	17	380	35	162	76	0,4
UTL 351 - 24	24	50	56	26	31	43	49	6	M6	17	420	35	148	71	0,4
UTL 351 - 25	25	50	56	26	31	43	49	6	M6	17	440	35	142	71	0,4
UTL 351 - 28	28	55	61	26	31	43	49	6	M6	17	490	35	127	65	0,5
UTL 351 - 30	30	55	61	26	31	43	49	6	M6	17	520	35	118	65	0,5
UTL 351 - 32	32	60	66	26	31	43	49	8	M6	17	740	46	148	79	0,6
UTL 351 - 35	35	60	66	26	31	43	49	8	M6	17	810	46	135	79	0,6
UTL 351 - 38	38	65	71	26	31	43	49	8	M6	17	880	46	125	73	0,8
UTL 351 - 40	40	65	71	26	31	43	49	8	M6	17	930	46	118	73	0,6
UTL 351 - 42	42	75	81	30	36	51	59	6	M8	41	1.350	64	135	76	1
UTL 351 - 45	45	75	81	30	36	51	59	6	M8	41	1.450	64	126	76	1
UTL 351 - 48	48	80	86	30	36	51	59	6	M8	41	1.540	64	119	71	1,1
UTL 351 - 50	50	80	86	30	36	51	59	6	M8	41	1.610	64	114	71	1,1
UTL 351 - 55	55	85	91	30	36	51	59	8	M8	41	2.360	86	138	89	1,1
UTL 351 - 60	60	90	96	30	36	51	59	8	M8	41	2.570	86	126	84	1,2
UTL 351 - 65	65	95	102	30	36	51	59	8	M8	41	2.790	86	117	80	1,3
UTL 351 - 70	70	110	117	40	46	59	69	8	M10	83	4.310	123	117	74	2,3
UTL 351 - 75	75	115	122	40	46	59	69	8	M10	83	4.620	123	109	71	2,4
UTL 351 - 80	80	120	127	40	46	59	69	8	M10	83	4.930	123	102	68	2,6
UTL 351 - 85	85	125	132	40	46	59	69	10	M10	83	5.990	141	110	75	2,7
UTL 351 - 90	90	130	137	40	46	59	69	10	M10	83	6.340	141	104	72	2,8
UTL 351 - 95	95	135	142	40	46	59	69	10	M10	83	8.360	176	123	86	3
UTL 351 - 100	100	145	153	46	52	70	82	8	M12	145	9.200	184	106	73	4,1
UTL 351 - 110	110	155	163	46	52	70	82	8	M12	145	10.100	184	96	68	4,4
UTL 351 - 120	120	165	173	46	52	70	82	10	M12	145	12.600	210	101	74	4,7
UTL 351 - 130	130	180	188	46	52	70	82	12	M12	145	17.100	263	117	84	5,7
UTL 351 - 140	140	190	199	51	59	82	86	8	M14	230	20.100	287	107	79	7
UTL 351 - 150	150	200	209	51	59	82	86	10	M14	230	26.900	359	124	93	7,2
UTL 351 - 160	160	210	219	51	59	82	86	10	M14	230	28.700	359	117	89	7,8
UTL 351 - 170	170	225	234	51	59	82	86	12	M14	230	36.600	430	132	100	9
UTL 351 - 180	180	235	244	51	59	82	86	12	M14	230	38.700	430	124	95	9,5
UTL 351 - 190	190	250	259	51	59	82	86	16	M14	230	51.100	538	147	112	10,57
UTL 351 - 200	200	260	269	51	59	82	86	16	M14	230	53.800	538	140	108	11,24
UTL 351 - 220	220	285	294	64	72	98	102	12	M16	355	65.100	592	111	86	14,8
UTL 351 - 240	240	305	314	64	72	98	102	16	M16	355	88.700	740	128	101	15,7
UTL 351 - 260	260	325	334	64	72	98	102	18	M16	355	115.400	887	141	113	17
UTL 351 - 280	280	355	364	75	83	121	127	16	M18	485	132.900	949	120	95	36
UTL 351 - 300	300	375	384	75	83	121	127	18	M18	485	160.200	1.068	126	101	37
UTL 351 - 320	320	405	414	90	98	140	148	18	M20	690	220.800	1.380	127	100	38,5
UTL 351 - 340	340	425	434	90	98	140	148	22	M20	690	273.700	1.610	140	112	40,4
UTL 351 - 360	360	455	464	110	118	164	174	18	M22	930	307.000	1.706	114	90	56,7
UTL 351 - 380	380	475	484	110	118	164	174	22	M22	930	378.100	1.990	126	101	58,8

Daha büyük çaplı UTL Konik Kilit ihtiyaçlarınız için bizi arayınız. / For assemblies requiring larger dimensions, contact our technical department.

UTL®

Standart Seri Konik Kilitler Standard Series Locking Assemblies

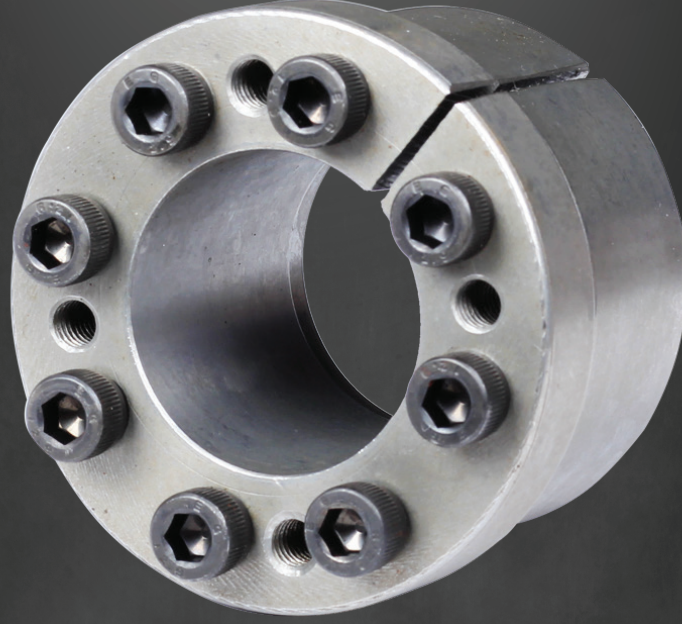

UTL - 351F



KENDİLİĞİNDEN YATAKLAYAN

UTL - 351F ; iki konik parça, bir aksenal kaymayı önleyici sabit flanş ve DIN 912 normlarına uygun bağlantı elemanlarından oluşmaktadır.

Yüksek tork gerektiren yerlerde uygulanması önerilir.

H8-h8 Tolerans - $Rt \leq 16 \mu m$

SELF-CENTERING

Locking assembly with single taper design. Provides good concentricity and self centering. It is recommended for high torques.

The flange design prevents axial movement during installation.

H8-h8 Tolerance - $Rt \leq 16 \mu m$

www.utl.com.tr

www.utllockingassemblies.com

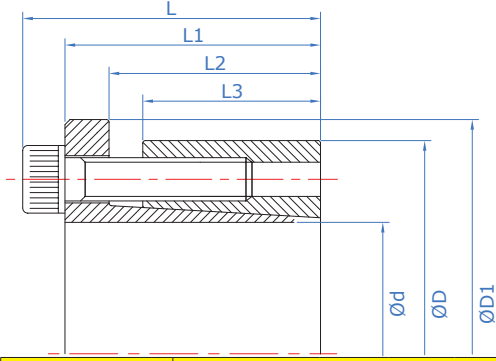

UTL - 351F Teknik Özellikler / Technical Properties

Ma	Vida sıkma döndürme momenti / Screw tightening torque
Mt	Maksimum aktarılabilen döndürme momenti (Fass=0 kN) / Transmissible torque moment
Fass	Maksimum aktarılabilen eksenel yük (Mt=0 Nm) / Transmissible axial load
Ps	Mile temas basıncı / Shaft pressure
Ph	Göbek çapına temas basıncı / Hub pressure

Sipariş Kodu / Code	Ölçüler / Dimensions							Bağlantı elemanları / Tightening screws		Başarımlar / Performances					Ağırlık / Weight kg
	d	D	D1	L3	L2	L1	L	DIN 912		Ma	Mt	Fass	Ps	Ph	
	mm	mm	mm	mm	mm	mm	mm	Ad.	12.9 TİP	Nm	Nm	kN	N/mm ²	N/mm ²	
UTL 351F - 20	20	47	53	26	30	42	48	6	M6	17	330	34	175	75	0,5
UTL 351F - 22	22	47	53	26	30	42	48	6	M6	17	370	34	160	75	0,5
UTL 351F - 24	24	50	56	26	31	43	49	6	M6	17	400	34	145	70	0,5
UTL 351F - 25	25	50	56	26	31	43	49	6	M6	17	420	34	140	70	0,5
UTL 351F - 28	28	55	61	26	31	43	49	6	M6	17	470	34	125	65	0,6
UTL 351F - 30	30	55	61	26	31	43	49	6	M6	17	510	34	115	65	0,6
UTL 351F - 32	32	60	66	26	31	43	49	8	M6	17	720	45	145	80	0,7
UTL 351F - 35	35	60	66	26	31	43	49	8	M6	17	790	45	135	80	0,6
UTL 351F - 38	38	65	71	26	31	43	49	8	M6	17	860	45	125	70	0,8
UTL 351F - 40	40	65	71	26	31	43	49	8	M6	17	900	45	120	70	0,6
UTL 351F - 42	42	75	81	30	36	51	59	6	M8	41	1.320	63	135	75	1,2
UTL 351F - 45	45	75	81	30	36	51	59	6	M8	41	1.410	63	125	75	1,1
UTL 351F - 48	48	80	86	30	36	51	59	6	M8	41	1.510	63	120	70	1,3
UTL 351F - 50	50	80	86	30	36	51	59	6	M8	41	1.570	63	110	70	1,1
UTL 351F - 55	55	85	91	30	36	51	59	8	M8	41	2.310	84	135	90	1,2
UTL 351F - 60	60	90	96	30	36	51	59	8	M8	41	2.520	84	124	85	1,3
UTL 351F - 65	65	95	102	30	36	51	59	8	M8	41	2.730	84	115	80	1,4
UTL 351F - 70	70	110	117	40	46	59	69	8	M10	83	4.650	133	125	80	2,5
UTL 351F - 75	75	115	122	40	46	59	69	8	M10	83	5.000	133	120	80	2,6
UTL 351F - 80	80	120	127	40	46	59	69	8	M10	83	5.330	133	110	75	2,8
UTL 351F - 85	85	125	132	40	46	59	69	10	M10	83	7.080	167	130	90	2,8
UTL 351F - 90	90	130	137	40	46	59	69	10	M10	83	7.500	167	125	85	3
UTL 351F - 95	95	135	142	40	46	59	69	10	M10	83	7.900	167	115	85	3
UTL 351F - 100	100	145	153	46	52	70	82	8	M12	145	9.700	194	115	80	5,5
UTL 351F - 110	110	155	163	46	52	70	82	8	M12	145	10.650	194	100	75	4,8
UTL 351F - 120	120	165	173	46	52	70	82	10	M12	145	14.550	243	120	85	5,5
UTL 351F - 130	130	180	188	46	52	70	82	12	M12	145	18.950	291	130	95	6
UTL 351F - 140	140	190	199	51	59	82	86	8	M14	230	18.650	267	100	75	7,5
UTL 351F - 150	150	200	209	51	59	82	86	10	M14	230	25.000	333	120	90	7,7
UTL 351F - 160	160	210	219	51	59	82	86	10	M14	230	26.650	333	110	85	8
UTL 351F - 170	170	225	234	51	59	82	86	12	M14	230	34.000	400	125	95	9,8
UTL 351F - 180	180	235	244	51	59	82	86	12	M14	230	36.000	400	120	90	9,8
UTL 351F - 190	190	250	259	51	59	82	86	15	M14	230	47.500	500	160	120	10
UTL 351F - 200	200	260	269	51	59	82	86	16	M14	230	50.000	500	150	115	10,5
UTL 351F - 220	220	285	294	64	72	98	102	12	M16	355	65.100	592	111	86	14,8
UTL 351F - 240	240	305	314	64	72	98	102	16	M16	355	88.700	740	128	101	15,7
UTL 351F - 260	260	325	334	64	72	98	102	18	M16	355	115.400	887	141	113	17
UTL 351F - 280	280	355	364	75	83	121	127	16	M18	485	132.900	949	120	95	36
UTL 351F - 300	300	375	384	75	83	121	127	15	M14	230	160.200	1.068	126	101	37
UTL 351F - 320	320	405	414	90	98	140	148	26	M16	355	220.800	1.380	127	100	38,5
UTL 351F - 340	340	425	434	90	98	140	148	30	M16	355	273.700	1.610	140	112	40,4
UTL 351F - 360	360	455	464	110	118	164	174	34	M16	355	307.000	1.706	114	90	56,7
UTL 351F - 380	380	475	484	110	118	164	174	32	M18	485	378.100	1.990	126	101	58,8

Daha büyük çaplı UTL Konik Kilit ihtiyaçlarınız için bizi arayınız. / For assemblies requiring larger dimensions, contact our technical department.

UTL®

Standart Seri Konik Kilitler Standard Series Locking Assemblies



UTL - 400



KENDİLİĞİNDEN YATAKLAYAN

UTL - 400 ; bir dış çember, iki konik yanak ve DIN 912 normlarına uygun bağlantı elemanlarından oluşmaktadır.

Yüksek tork gerektiren yerlerde uygulanması önerilir.

H8-h8 Tolerans - $Rt \leq 16 \mu m$



SELF-CENTERING

It is suitable for high torques and is self-centering.

Recommended for applications that requires high transmission values and excellent centering capabilities such as belt drums.

H8-h8 Tolerance - $Rt \leq 16 \mu m$

www.utl.com.tr

www.utllockingassemblies.com

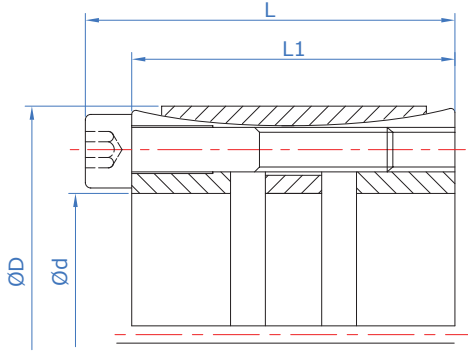

UTL - 400 Teknik Özellikler / Technical Properties

Ma	Vida sıkma döndürme momenti / Screw tightening torque
Mt	Maksimum aktarılabilen döndürme momenti (Fass=0 kN) / Transmissible torque moment
Fass	Maksimum aktarılabilen eksenel yük (Mt=0 Nm) / Transmissible axial load
Ps	Mile temas basıncı / Shaft pressure
Ph	Göbek çapına temas basıncı / Hub pressure

Sipariş Kodu / Code	Ölçüler / Dimensions				Bağlantı elemanları / Tightening screws		Başarımlar / Performances					Ağırlık / Weight kg
	d	D	L1	L	DIN 912		Ma	Mt	Fass	Ps	Ph	
	mm	mm	mm	mm	Ad.	12.9 TİP	Nm	Nm	kN	N/mm ²	N/mm ²	
UTL400 - 70	70	110	62	72	8	M10	83	7.280	208	197	125	2,30
UTL400 - 80	80	120	62	72	10	M10	83	10.400	260	216	144	2,50
UTL400 - 90	90	130	62	72	11	M10	83	12.900	286	211	146	2,70
UTL400 - 100	100	145	72	84	10	M12	145	19.400	388	215	148	4,10
UTL400 - 110	110	155	72	84	10	M12	145	21.400	388	195	138	4,40
UTL400 - 120	120	165	72	84	11	M12	145	25.600	427	197	143	4,80
UTL400 - 130	130	180	82	94	14	M12	145	33.500	544	205	148	6,30
UTL400 - 140	140	190	82	94	15	M12	145	40.800	582	204	151	6,60
UTL400 - 150	150	200	82	94	15	M12	145	43.700	582	191	143	7,80
UTL400 - 160	160	210	82	94	16	M12	145	49.700	621	191	145	7,40
UTL400 - 170	170	225	93	107	15	M14	230	67.500	795	194	146	10,70
UTL400 - 180	180	235	93	107	15	M14	230	71.500	795	183	140	11,30
UTL400 - 190	190	250	105	119	16	M14	230	80.500	848	156	118	14,60
UTL400 - 200	200	260	105	119	18	M14	230	95.300	950	166	128	15,30
UTL400 - 220	220	285	111	127	15	M16	355	119.000	1.080	159	123	20,20
UTL400 - 240	240	305	111	127	20	M16	355	173.000	1.440	194	153	21,80
UTL400 - 260	260	325	111	127	21	M16	355	196.800	1.510	188	151	23,40
UTL400 - 280	280	355	111	131	15	M20	690	237.300	1.690	211	167	30,00
UTL400 - 300	300	375	111	131	15	M20	690	254.200	1.690	197	158	31,20
UTL400 - 320	320	405	136	156	20	M20	690	361.500	2.260	195	154	48,00
UTL400 - 340	340	425	136	156	20	M20	690	384.100	2.260	184	147	51,00
UTL400 - 360	360	455	160	182	20	M22	930	498.700	2.770	170	135	69,00
UTL400 - 380	380	475	160	182	22	M22	930	526.400	2.770	161	129	73,00
UTL400 - 400	400	495	160	182	24	M22	930	609.500	3.050	168	136	76,00
UTL400 - 420	420	515	160	182	24	M22	930	698.200	3.320	175	143	80,00
UTL400 - 440	440	535	160	182	24	M22	930	731.400	3.320	167	137	81,00
UTL400 - 460	460	555	160	182	24	M22	930	764.700	3.320	160	132	85,00
UTL400 - 480	480	575	160	182	25	M22	930	831.200	3.460	159	133	88,00
UTL400 - 500	500	595	160	182	25	M22	930	866.000	3.460	153	129	91,00
UTL400 - 520	520	615	160	182	28	M22	930	1.008.000	3.880	165	139	95,00
UTL400 - 540	540	635	160	182	28	M22	930	1.047.000	3.880	159	135	98,00
UTL400 - 560	560	655	160	182	30	M22	930	1.164.000	4.160	164	140	101,00
UTL400 - 580	580	675	160	182	30	M22	930	1.205.000	4.160	158	136	104,00
UTL400 - 600	600	695	160	182	30	M22	930	1.247.000	4.160	153	132	108,00

UTL®

Standart Seri Konik Kilitler Standard Series Locking Assemblies



UTL - 401



KENDİLİĞİNDEN YATAKLAYAN

UTL - 401 ; bir dış çember, iki konik yanak ve DIN 912 normlarına uygun bağlantı elemanlarından oluşmaktadır.

Çok yüksek tork gerektiren yerlerde uygulanması önerilir.

H8-h8 Tolerans - $R_t \leq 16 \mu m$

SELF-CENTERING

It is suitable for very high torques and is self-centering.

Recommended for applications that requires high transmission values and excellent centering capabilities such as belt drums.

H8-h8 Tolerance - $R_t \leq 16 \mu m$

www.utl.com.tr

www.utllockingassemblies.com

UTL - 401 Teknik Özellikler / Technical Properties

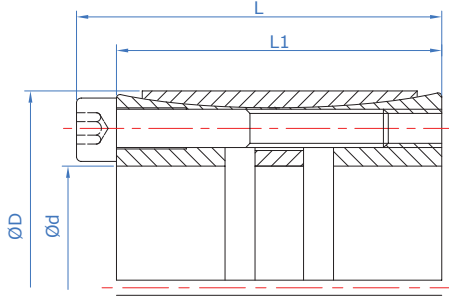

Ma	Vida sıkma döndürme momenti / Screw tightening torque
Mt	Maksimum aktarılabilen döndürme momenti (Fass=0 kN) / Transmissible torque moment
Fass	Maksimum aktarılabilen eksenel yük (Mt=0 Nm) / Transmissible axial load
Ps	Mile temas basıncı / Shaft pressure
Ph	Göbek çapına temas basıncı / Hub pressure

Sipariş Kodu / Code	Ölçüler / Dimensions				Bağlantı elemanları / Tightening screws		Başarımlar / Performances					Ağırlık / Weight kg
	d	D	L1	L	DIN 912		Ma	Mt	Fass	Ps	Ph	
	mm	mm	mm	mm	Ad.	12.9 TİP	Nm	Nm	kN	N/mm ²	N/mm ²	
UTL 401 - 24	24	55	40	46	6	M6	17	800	67	308	134	0,50
UTL 401 - 25	25	55	40	46	6	M6	17	840	67	295	134	0,50
UTL 401 - 28	28	55	40	46	6	M6	17	940	67	264	134	0,60
UTL 401 - 30	30	55	40	46	6	M6	17	1.000	67	246	134	0,60
UTL 401 - 32	32	60	54	60	7	M6	17	1.250	78	190	101	0,70
UTL 401 - 35	35	60	54	60	7	M6	17	1.360	78	174	101	0,70
UTL 401 - 38	38	75	54	62	7	M8	41	2.740	144	296	150	0,70
UTL 401 - 40	40	75	54	62	7	M8	41	2.880	144	281	150	0,70
UTL 401 - 42	42	75	54	62	7	M8	41	3.030	144	268	150	1,00
UTL 401 - 45	45	75	54	62	7	M8	41	3.240	144	250	150	0,90
UTL 401 - 48	48	80	66	74	8	M8	41	3.950	165	207	124	1,40
UTL 401 - 50	50	80	66	74	8	M8	41	4.120	165	198	124	1,30
UTL 401 - 55	55	85	66	74	9	M8	41	5.090	185	203	131	1,50
UTL 401 - 60	60	90	66	74	10	M8	41	6.140	206	208	138	1,60
UTL 401 - 65	65	95	66	74	10	M8	41	6.690	206	191	131	1,80
UTL 401 - 70	70	110	80	90	10	M10	83	11.800	338	229	145	3,00
UTL 401 - 75	75	115	80	90	10	M10	83	12.700	338	213	139	3,30
UTL 401 - 80	80	120	80	90	11	M10	83	14.900	372	220	147	3,50
UTL 401 - 85	85	125	80	90	11	M10	83	15.800	372	207	141	3,70
UTL 401 - 90	90	130	80	90	12	M10	83	18.200	405	213	148	3,80
UTL 401 - 95	95	135	80	90	12	M10	83	19.300	405	202	142	5,00
UTL 401 - 100	100	145	102	114	11	M12	145	27.700	555	210	145	6,00
UTL 401 - 110	110	155	102	114	12	M12	145	33.300	605	209	148	6,20
UTL 401 - 120	120	165	102	114	14	M12	145	42.400	706	223	162	7,20
UTL 401 - 130	130	180	116	130	12	M14	230	53.700	826	201	145	10,00
UTL 401 - 140	140	190	116	130	14	M14	230	67.400	963	217	160	10,20
UTL 401 - 150	150	200	116	130	15	M14	230	77.400	1.030	217	163	10,80
UTL 401 - 160	160	210	116	130	16	M14	230	88.100	1.100	217	166	11,50
UTL 401 - 170	170	225	149	165	14	M16	355	111.500	1.310	186	141	17,00
UTL 401 - 180	180	235	149	165	15	M16	355	126.500	1.410	188	144	18,50
UTL 401 - 190	190	250	149	165	16	M16	355	142.400	1.500	190	145	21,50
UTL 401 - 200	200	260	149	165	16	M16	355	149.900	1.500	181	139	22,00
UTL 401 - 220	220	285	150	166	18	M16	355	185.500	1.690	185	143	26,59
UTL 401 - 240	240	305	150	166	20	M16	355	224.800	1.870	188	148	28,70
UTL 401 - 260	260	325	150	166	21	M16	690	255.700	1.970	182	146	31,23
UTL 401 - 280	280	355	177	197	18	M20	690	369.900	2.640	190	150	46,77
UTL 401 - 300	300	375	177	197	20	M20	690	440.300	2.940	197	157	49,00



UTL - 100M



KENDİLİĞİNDEN YATAKLAYAN

UTL - 100M ; iki konik parça, bir çember ve DIN 912 normlarına uygun bağlantı elemanlarından oluşmaktadır.

Orta ve yüksek tork gerektiren yerlerde ve küçük çaplı uygulamalarda önerilir.

H8-h8 Tolerans - $R_t \leq 16 \mu\text{m}$

SELF-CENTERING

Locking assembly with single taper design. Consists of two tapered rings and a spacer. It has minimum overall dimensions in virtue of the reduced thickness of the cones. UTL - 100M is suitable for the applications where small hubs are requested. It is recommended for mid-high torques and is self centering.

H8-h8 Tolerance - $R_t \leq 16 \mu\text{m}$

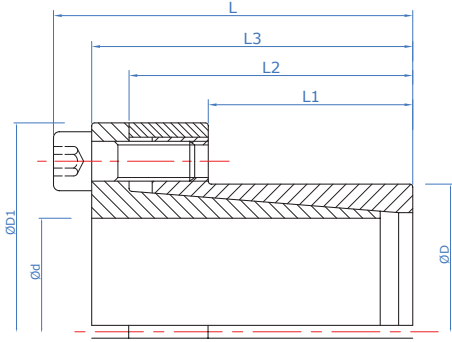

UTL - 100M Teknik Özellikler / Technical Properties

M_A	Vida sıkma döndürme momenti / Screw tightening torque
M_t	Maksimum aktarılabilen döndürme momenti ($F_{ass}=0$ kN) / Transmissible torque moment
F_{ass}	Maksimum aktarılabilen aksel yük ($M_t=0$ Nm) / Transmissible axial load
P_s	Mile temas basıncı / Shaft pressure
P_h	Göbek çapına temas basıncı / Hub pressure

Sipariş Kodu / Code	Ölçüler / Dimensions							Bağlantı elemanları / Tightening screws		Başarımlar / Performances					Ağırlık / Weight kg
	d	D	L1	L2	L3	L	D1	DIN 912		M_A	M_t	F_{ass}	P_s	P_h	
	mm	mm	mm	mm	mm	mm	mm	Ad.	12.9 TİP	Nm	Nm	kN	N/mm ²	N/mm ²	
UTL 100 M - 6	6	14	10	18,5	21	24	25	3	M3	2	12	4	185	80	0,04
UTL 100 M - 7	7	15	12	22	25	29	27	3	M4	5	25	7	235	110	0,06
UTL 00 M - 8	8	15	12	22	25	29	27	3	M4	5	29	7	205	110	0,05
UTL 100 M - 9	9	16	14	23	26	30	28	4	M4	5	44	10	205	115	0,06
UTL 100 M - 10	10	16	14	23	26	30	28	4	M4	5	49	10	185	115	0,06
UTL 100 M - 11	11	18	14	23	26	30	32	4	M4	5	53	10	170	105	0,07
UTL 100 M - 12	12	18	14	23	26	30	32	4	M4	5	58	10	160	105	0,07
UTL 100 M - 13	13	23	14	23	26	30	38	4	M4	5	63	10	140	80	0,11
UTL 100 M - 14	14	23	14	23	26	30	38	4	M4	5	68	10	130	80	0,1
UTL 100 M - 15	15	24	16	29	36	42	45	3	M6	17	127	17	185	115	0,22
UTL 100 M - 16	16	24	16	29	36	42	45	3	M6	17	136	17	175	115	0,22
UTL 100 M - 17	17	26	18	31	38	44	47	4	M6	17	180	22	190	125	0,25
UTL 100 M - 18	18	26	18	31	38	44	47	4	M6	17	200	22	180	125	0,24
UTL 100 M - 19	19	27	18	31	38	44	49	4	M6	17	210	22	170	120	0,26
UTL 100 M - 20	20	28	18	31	38	44	50	4	M6	17	220	22	160	115	0,27

UTL®

Mini Seri
Mini Series



UTL - 201M



KENDİLİĞİNDEN YATAKLAYAN

UTL - 201M ; İki konik parça ve DIN 912 normlarına uygun bağlantı elemanlarından oluşmaktadır.

Düşük ve orta tork gerektiren yerlerde uygulanması önerilir.

H8 - h8 Tolerans - $R_t \leq 16\mu\text{m}$

SELF-CENTERING

UTL - 201M ; It consists of two conical parts and fasteners in accordance with DIN 912 norms.

It is recommended to be applied in places that require low and medium torque.

H8 - h8 Tolerance - $R_t \leq 16\mu\text{m}$

www.utl.com.tr

www.utllockingassemblies.com

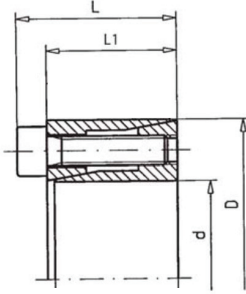

UTL - 201M Teknik Özellikler / Technical Properties

Ma	Vida sıkma döndürme momenti / Screw tightening torque
Mt	Maksimum aktarılabilen döndürme momenti (Fass=0 kN) / Transmissible torque moment
Fass	Maksimum aktarılabilen aksenal yük (Mt=0 Nm) / Transmissible axial load
Ps	Mile temas basıncı / Shaft pressure
Ph	Göbek çapına temas basıncı / Hub pressure

Sipariş Kodu / Code	Öçüler / Dimensions				Bağlantı elemanları / Tightening screws		Başarımlar / Performances					Ağırlık / Weight kg
	d	D	L1	L	DIN 912		Ma	Mt	Fass	Ps	Ph	
	mm	mm	mm	mm	Adet	12.9 TİP	Nm	Nm	kN	N/mm ²	N/mm ²	
UTL 201M - 5	5	16	11	13,5	3	M2,5	1,2	7	2,80	205	64	0,012
UTL 201M - 6	6	16	11	13,5	3	M2,5	1,2	8	2,80	171	64	0,012
UTL 201M - 6,35	6,35	16	11	13,5	3	M2,5	1,2	9	2,80	161	64	0,012
UTL 201M - 7	7	17	11	13,5	3	M2,5	1,2	10	2,80	146	60	0,013
UTL 201M - 8	8	18	11	13,5	3	M2,5	1,2	11	2,80	128	57	0,015
UTL 201M - 9	9	20	13	15,5	4	M2,5	1,2	17	3,70	135	61	0,02
UTL 201M - 9,53	9,53	20	13	15,5	4	M2,5	1,2	18	3,70	127	61	0,02
UTL 201M - 10	10	20	13	15,5	4	M2,5	1,2	19	3,70	121	61	0,02
UTL 201M - 11	11	22	13	15,5	4	M2,5	1,2	21	3,70	110	55	0,024
UTL 201M - 12	12	22	13	15,5	4	M2,5	1,2	22	3,70	101	55	0,022
UTL 201M - 12,7	12,7	22	13	15,5	4	M2,5	1,2	24	4,00	104	56	0,022
UTL 201M - 14	14	26	17	20	4	M3	2,2	40	5,70	99	53	0,039
UTL 201M - 15	15	28	17	20	4	M3	2,2	43	5,70	93	50	0,044
UTL 201M - 16	16	32	17	21	4	M4	4,9	75	9,50	145	73	0,067
UTL 201M - 17	17	35	21	25	4	M4	4,9	80	9,50	117	57	0,09
UTL 201M - 18	18	35	21	25	4	M4	4,9	85	9,50	111	57	0,087
UTL 201M - 19	19	35	21	25	4	M4	4,9	90	9,50	105	57	0,083
UTL 201M - 20	20	38	21	26	4	M5	10	155	16,00	162	85	0,1
UTL 201M - 22	22	40	21	26	4	M5	10	170	16,00	148	81	0,11
UTL 201M - 24	24	47	26	32	4	M6	17	265	22,00	149	76	0,2
UTL 201M - 25	25	47	26	32	4	M6	17	275	22,00	143	76	0,19
UTL 201M - 25,4	25,4	47	26	32	4	M6	17	280	28,00	141	76	0,18
UTL 201M - 28	28	50	26	32	6	M6	17	460	33,00	192	107	0,22



UTL - 350FM



KENDİLİĞİNDEN YATAKLAYAN

UTL - 350FM ; iki konik parça, bir çember ve DIN 912 normlarına uygun bağlantı elemanlarından oluşmaktadır.

Orta ve yüksek tork gerektiren yerlerde ve küçük çaplı uygulamalarda önerilir.

H8-h8 Tolerans - $R_t \leq 16 \mu m$

SELF-CENTERING

Locking assembly with single taper design. Consists of two tapered rings and a spacer. It has minimum overall dimensions in virtue of the reduced thickness of the cones. UTL - 350FM is suitable for the applications where small hubs are requested. It is recommended for mid-high torques and is self centering.

H8-h8 Tolerance - $R_t \leq 16 \mu m$

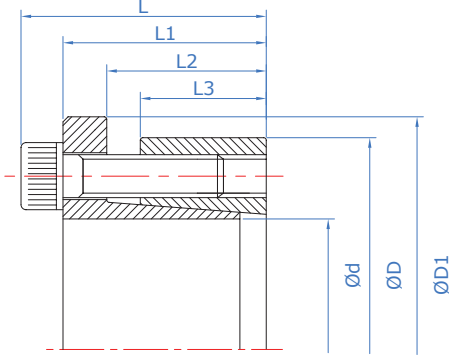

UTL - 350FM Teknik Özellikler / Technical Properties

Ma	Vida sıkma döndürme momenti / Screw tightening torque
Mt	Maksimum aktarılabilen döndürme momenti (Fass=0 kN) / Transmissible torque moment
Fass	Maksimum aktarılabilen aksenal yük (Mt=0 Nm) / Transmissible axial load
Ps	Mile temas basıncı / Shaft pressure
Ph	Göbek çapına temas basıncı / Hub pressure

Sipariş Kodu / Code	Ölçüler / Dimensions							Bağlantı elemanları / Tightening screws		Başarımlar / Performances				
	d	D	D1	L3	L2	L1	L	DIN 912		Ma	Mt	Fass	Ps	Ph
	mm	mm	mm	mm	mm	mm	mm	Ad.	12.9 TİP	Nm	Nm	kN	N/mm	N/mm
UTL 350FM - 6	6	22	25	11	13	21	21	4	M4	5	22	7,3	323	88
UTL 350FM - 7	7	22	25	11	13	21	21	4	M4	5	26	7,3	277	88
UTL 350FM - 8	8	22	25	11	13	21	21	4	M4	5	29	7,3	242	88
UTL 350FM - 9	9	25	28	11	13	21	21	4	M4	5	33	7,3	215	77
UTL 350FM - 10	10	25	28	11	13	21	21	4	M4	5	37	7,3	194	77
UTL 350FM - 11	11	27	30	11	13	21	21	4	M4	5	54	9,7	235	96
UTL 350FM - 12	12	27	30	11	13	21	21	4	M4	5	58	9,7	215	96
UTL 350FM - 14	14	30	33	13	15	23	23	4	M4	5	102	14,6	231	108
UTL 350FM - 15	15	30	33	13	15	23	23	4	M4	5	110	14,6	215	108
UTL 350FM - 16	16	30	33	13	15	23	23	4	M4	5	117	14,6	202	108
UTL 350FM - 17	17	34	37	13	15	23	23	4	M4	5	124	14,3	190	95
UTL 350FM - 18	18	34	37	13	16	23	24	4	M4	5	131	14,3	179	95
UTL 350FM - 19	19	34	37	13	16	24	24	4	M4	5	139	14,3	170	95
UTL 350FM - 20	20	40	45	16	19	24	29	4	M5	10	235	23,5	207	104
UTL 350FM - 22	22	40	45	16	19	29	29	4	M5	10	258	23,5	189	104
UTL 350FM - 24	24	43	48	16	19	29	29	4	M5	10	375	31,5	230	129
UTL 350FM - 25	25	43	48	16	19	29	29	4	M5	10	391	31,5	221	129
UTL 350FM - 28	28	50	55	18	21	29	31	4	M5	10	547	39,5	218	122
UTL 350FM - 30	30	50	55	18	21	31	31	4	M5	10	586	39,5	203	122
UTL 350FM - 32	32	55	60	18	21	31	31	4	M5	10	625	39,5	191	111
UTL 350FM - 35	35	55	60	18	21	31	31	4	M5	10	684	39,5	174	111



UTL - 501M



MİNİ SERİ RİJİT KAPLİN

UTL - 501M ; iki konik yanak, bir iç çember ve DIN 931 normlarına uygun bağlantı elemanlarından oluşmaktadır.

Yüksek tork gerektiren yerlerde uygulanması önerilir. Milden mile bağlantı yapmak için tasarlanmıştır. Farklı çaplı millerde de uygulanabilmektedir.

h8 Tolerans - $R_t \leq 16 \mu\text{m}$

MINI SERIES RIGID COUPLING

UTL - 501M are rigid couplings for shaft to shaft connections.

They offer easy angular timing and axial adjustment of shaft ends. They transmit high torque and bending moment without keys and offer a low cost solution for shaft to shaft rigid connection.

Double diameter versions are available.

h8 Tolerance - $R_t \leq 16 \mu\text{m}$

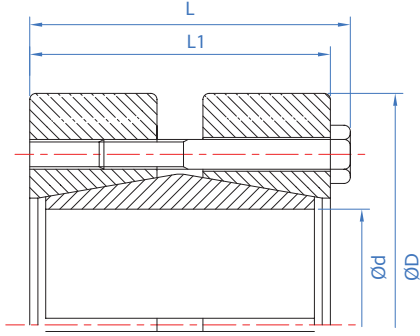

UTL - 501M Teknik Özellikler / Technical Properties

Ma	Vida sıkma döndürme momenti / Screw tightening torque
Mt	Maksimum aktarılabilen döndürme momenti (Fass=0 kN) / Transmissible torque moment
Fass	Maksimum aktarılabilen aksel yük (Mt=0 Nm) / Transmissible axial load
Ps	Mile temas basıncı / Shaft pressure
Ph	Göbek çapına temas basıncı / Hub pressure

Sip.kodu / Code	Ölçüler / Dimensions				Bağlantı elemanları/ Tightenin screws		Başarımlar / Performances				Ağırlık / Weight Kg
	d	D	L1	L	DIN 931		Ma	Mt	Fass	Ps	
	mm	mm	mm	mm	Adet	10.9 TİP	Nm	Nm	kN	N/mm ²	
UTL 501M - 6	6	35	19	23	3	M5	4	27	9	491	0,11
UTL 501M - 7	7	35	19	23	3	M5	4	31	9	421	0,11
UTL 501M - 8	8	35	19	23	3	M5	4	36	9	368	0,11
UTL 501M - 9	9	39	23	27	3	M5	4	50	11	327	0,17
UTL 501M - 10	10	39	23	27	4	M5	4	55	11	294	0,17
UTL 501M - 11	11	39	23	27	4	M5	4	61	11	268	1,17
UTL 501M - 12	12	44	30	34	4	M5	4	80	13	226	0,29
UTL 501M - 13	13	44	30	34	4	M5	4	87	13	209	0,29
UTL 501M - 14	14	44	30	34	4	M5	4	93	13	194	0,29

UTL®

Mini Seri
Mini Series



UTL - 550M



MİNİ SERİ ŞİRİNK DİSK

UTL - 550M ; iki konik parça, bir çember ve DIN 931 normlarına uygun bağlantı elemanlarından oluşmaktadır.

Orta ve yüksek tork gerektiren yerlerde ve küçük çaplı uygulamalarda önerilir.

H8-h8 Tolerans - $Rt \leq 16 \mu m$

MINI SERIES SHRINK DISCS

Locking assembly with single taper design. Consists of two tapered rings and a spacer. It has minimum overall dimensions in virtue of the reduced thickness of the cones. UTL - 550M is suitable for the applications where small hubs are requested. It is recommended for mid-high torques and is self centering.

H8-h8 Tolerance - $Rt \leq 16 \mu m$

www.utl.com.tr

www.utllockingassemblies.com

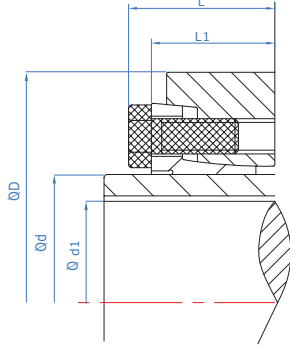

UTL - 550M Teknik Özellikler / Technical Properties

Ma	Vida sıkma döndürme momenti / Screw tightening torque
Mt	Maksimum aktarılabilen döndürme momenti (Fass=0 kN) / Transmissible torque moment
Fass	Maksimum aktarılabilen aksel yük (Mt=0 Nm) / Transmissible axial load
Ps	Mile temas basıncı / Shaft pressure
Ph	Göbek çapına temas basıncı / Hub pressure

Sipariş Kodu / Code	Ölçüler / Dimensions					Bağlantı elemanları/ Tightenin screws		Başarımlar / Performances			Ağırlık / Weight Kg
	d1	d	D	L1	L	DIN 931		Ma	Mt	Fass	
	mm	mm	mm	mm	mm	Ad	10.9 TİP	Nm	Nm	kN	
UTL550 M - 9	9	12	35	11	15	3	M6	12	20	5	0,1
UTL 550 M-10	10	12	35	11	15	3	M6	12	40	8	0,1
UTL 550 M-11	11	14	38	11	15	3	M6	12	30	6	0,1
UTL 550 M-12	12	14	38	11	15	3	M6	12	50	9	0,1
UTL 550 M-13	13	16	41	15	19	3	M6	12	70	10	0,1
UTL 550 M-14	14	16	41	15	19	3	M6	12	90	13	0,1
UTL 550 M-15	15	18	44	15	19	4	M6	12	80	11	0,1
UTL 550 M-16	16	18	44	15	19	4	M6	12	110	14	0,1
UTL 550 M-17	17	20	47	15	19	4	M6	12	150	18	0,2
UTL 550 M-18	18	20	47	15	19	4	M6	12	180	20	0,2



200 Plus



KENDİLİĞİNDEN YATAKLAMAYAN

200 Plus ; dış ve iç çember, iki konik yanak ve DIN 912 normlarına uygun bağlantı elemanlarından oluşmaktadır.

Orta ve yüksek tork gerektiren yerlerde, çok amaçlı olarak uygulanması önerilir.

H8-h8 Tolerans - $R_t \leq 16 \mu\text{m}$



NOT SELF-CENTERING

200 Plus locking assembly unit consists of four pieces with two inside double-cone rings joined through a set of tightening screws.

It is recommended for medium torques. Although it is not self centering, it can be easily assembled and disassembled.

H8-h8 Tolerance - $R_t \leq 16 \mu\text{m}$

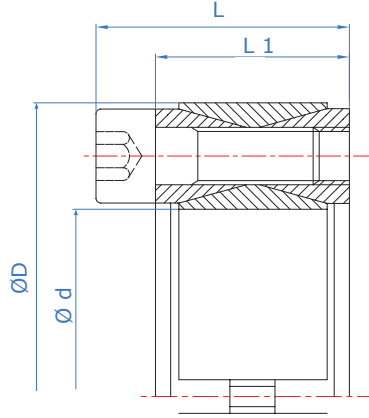

200 Plus Teknik Özellikler / Technical Properties

Ma	Vida sıkma döndürme momenti / Screw tightening torque
Mt	Maksimum aktarılabilen döndürme momenti (Fass=0 kN) / Transmissible torque moment
Fass	Maksimum aktarılabilen aksel yük (Mt=0 Nm) / Transmissible axial load
Ps	Mile temas basıncı / Shaft pressure
Ph	Göbek çapına temas basıncı / Hub pressure

Sipariş Kodu / Code	Ölçüler / Dimensions				Bağlantı elemanları / Tightening screws		Başarımlar / Performances					Ağırlık / Weight kg
	d	D	L1	L	DIN 912		Ma	Mt	Fass	Ps	Ph	
	mm	mm	mm	mm	Ad.	12.9 TİP	Nm	Nm	kN	N/mm ²	N/mm ²	
200 Plus - 180	180	235	44	60	24	M14	230	38.700	431	170	130	6,0
200 Plus - 190	190	250	52	68	28	M14	230	44.700	502	155	120	8,5
200 Plus - 200	200	260	52	68	30	M14	230	53.500	538	155	120	8,6
200 Plus - 220	220	285	56	74	26	M16	300	68.500	630	155	120	11
200 Plus - 240	240	305	56	74	30	M16	300	86.000	717	165	130	12
200 Plus - 260	260	325	56	74	34	M16	300	105.000	810	165	135	13
200 Plus - 280	280	355	66	86	32	M18	410	128.500	920	150	120	19
200 Plus - 300	300	375	66	86	36	M18	410	153.600	1.025	155	125	20

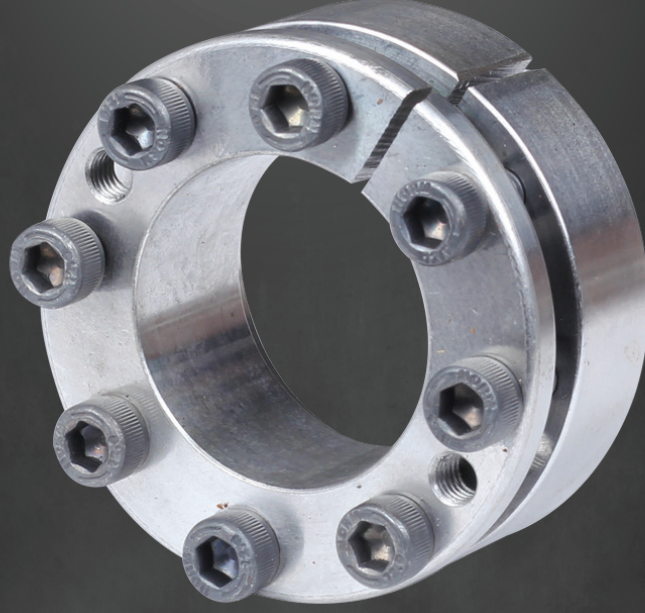

300 Plus



KENDİLİĞİNDEN YATAKLAYAN

300 Plus ; iki konik parça ve DIN 912 normlarına uygun bağlantı elemanlarından oluşmaktadır.

Orta tork gerektiren yerlerde uygulanması önerilir.

H8-h8 Tolerans - $Rt \leq 16 \mu m$

SELF-CENTERING

Locking assembly with single taper design. Provides good concentricity and is self centering. A small axial movement of the hub during the installation operation may occur. Applications requiring accurate axial positioning are not recommended with this type of locking assembly. 300 Plus is suitable for applications with medium torques.

H8-h8 Tolerance - $Rt \leq 16 \mu m$

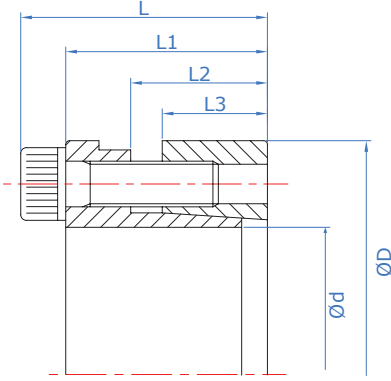

300 Plus Teknik Özellikler / Technical Properties

Ma	Vida sıkma döndürme momenti / Screw tightening torque
Mt	Maksimum aktarılabilen döndürme momenti (Fass=0 kN) / Transmissible torque moment
Fass	Maksimum aktarılabilen eksenel yük (Mt=0 Nm) / Transmissible axial load
Ps	Mile temas basıncı / Shaft pressure
Ph	Göbek çapına temas basıncı / Hub pressure

Sipariş Kodu / Code	Ölçüler / Dimensions						Bağlantı elemanları / Tightening screws		Başarımlar / Performances					Ağırlık / Weight kg
	d	D	L3	L2	L1	L	DIN 912		Ma	Mt	Fass	Ps	Ph	
	mm	mm	mm	mm	mm	mm	Ad.	12.9 TİP	Nm	Nm	kN	N/mm ²	N/mm ²	
300 Plus - 100	100	145	26	32	44	56	8	M12	125	13.400	268	270	190	2,8
300 Plus - 110	110	155	26	32	44	56	8	M12	125	14.600	268	240	180	3
300 Plus - 120	120	165	26	32	44	56	9	M12	125	17.900	298	250	180	3,2
300 Plus - 130	130	180	34	40	54	66	12	M12	125	26.000	400	240	170	4,8
300 Plus - 140	140	190	34	40	54	68	9	M14	190	27.000	384	210	150	5,2
300 Plus - 150	150	200	34	40	54	68	10	M14	190	33.000	440	230	170	5,4
300 Plus - 160	160	210	34	40	54	68	11	M14	190	38.000	479	230	170	5,7
300 Plus - 170	170	225	44	50	64	78	12	M14	190	45.000	530	180	130	8
300 Plus - 180	180	235	44	50	64	78	12	M14	190	47.000	530	170	130	8,3
300 Plus - 190	190	250	44	50	64	78	15	M14	190	62.900	660	170	115	9,6
300 Plus - 200	200	260	44	50	64	78	15	M14	190	73.700	625	160	130	10
300 Plus - 220	220	285	50	56	75	91	12	M16	295	63.700	579	140	120	13,4
300 Plus - 240	240	305	50	56	75	91	15	M16	295	87.000	725	160	110	14,3
300 Plus - 260	260	325	50	56	75	91	18	M16	295	113.000	869	180	125	15,5
300 Plus - 280	280	355	60	66	87	105	16	M18	405	131.500	930	150	140	22
300 Plus - 300	300	375	60	66	87	105	18	M18	405	158.500	1.060	155	120	24,4
300 Plus - 320	320	405	74	81	104	124	18	M20	580	218.000	1.363	155	125	36,1
300 Plus - 340	340	425	74	81	104	124	21	M20	580	270.000	1.588	170	135	38,4
300 Plus - 360	360	455	86	94	120	142	18	M22	780	305.000	1.694	145	115	46,2



301 Plus



KENDİLİĞİNDEN YATAKLAYAN

301 Plus ; iki konik parça ve DIN 912 normlarına uygun bağlantı elemanlarından oluşmaktadır.

Yüksek tork gerektiren yerlerde uygulanması önerilir.

H8-h8 Tolerans - $R_t \leq 16 \mu\text{m}$

SELF-CENTERING

Locking assembly with single taper design. It is suitable for high torques. Provide good concentricity and self centering. A small axial movement of the hub during the installation operation may occur.

Applications in need of an accurate axial positioning are not recommended with this type of locking assembly.

H8-h8 Tolerance - $R_t \leq 16 \mu\text{m}$

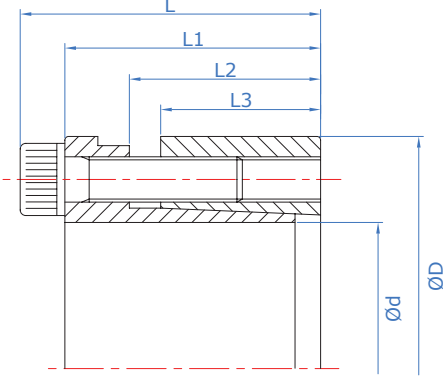

301 Plus Teknik Özellikler / Technical Properties

Ma	Vida sıkma döndürme momenti / Screw tightening torque
Mt	Maksimum aktarılabilen döndürme momenti (Fass=0 kN) / Transmissible torque moment
Fass	Maksimum aktarılabilen eksenel yük (Mt=0 Nm) / Transmissible axial load
Ps	Mile temas basıncı / Shaft pressure
Ph	Göbek çapına temas basıncı / Hub pressure

Sipariş Kodu / Code	Ölçüler / Dimensions						Bağlantı elemanları / Tightening screws		Başarımlar / Performances					Ağırlık / Weight kg
	d	D	L3	L2	L1	L	DIN 912		Ma	Mt	Fass	Ps	Ph	
	mm	mm	mm	mm	mm	mm	Ad.	12.9 TİP	Nm	Nm	kN	N/mm ²	N/mm ²	
301 Plus - 100	100	145	46	52	68	80	8	M12	145	15.580	312	180	125	3,9
301 Plus - 110	110	155	46	52	68	80	8	M12	145	17.100	312	165	115	4,2
301 Plus - 120	120	165	46	52	68	80	10	M12	145	23.370	390	190	135	4,8
301 Plus - 130	130	180	46	52	68	80	12	M12	145	30.380	467	210	150	5
301 Plus - 140	140	190	50	57	76	90	8	M14	230	29.900	428	165	120	6,5
301 Plus - 150	150	200	50	57	76	90	10	M14	230	40.000	535	190	145	7
301 Plus - 160	160	210	50	57	76	90	10	M14	230	42.750	535	180	135	7
301 Plus - 170	170	225	50	57	76	90	12	M14	230	54.500	641	200	150	8,5
301 Plus - 180	180	235	50	57	76	90	12	M14	230	57.700	641	190	145	9
301 Plus - 190	190	250	50	57	76	90	16	M14	230	72.000	750	230	165	10,57
301 Plus - 200	200	260	50	57	76	90	16	M14	230	76.000	750	210	165	11,24
301 Plus - 220	220	285	64	72	98	102	12	M16	355	65.400	655	254	195	14,8
301 Plus - 240	240	305	64	72	98	102	16	M16	355	107.000	888	267	210	15,7
301 Plus - 260	260	325	64	72	98	102	18	M16	355	130.000	1.001	279	223	17
301 Plus - 280	280	355	75	83	121	127	16	M18	485	158.000	1.128	245	193	36
301 Plus - 300	300	375	75	83	121	127	18	M18	485	190.000	1.264	257	206	37
301 Plus - 320	320	405	90	98	140	148	18	M20	690	260.000	1.627	259	205	38,5
301 Plus - 340	340	425	90	98	140	148	22	M20	690	275.000	1.620	244	195	40,4
301 Plus - 360	360	455	110	118	164	174	18	M22	930	356.000	1.980	242	192	56,7



400 Plus



KENDİLİĞİNDEN YATAKLAYAN

400 Plus ; bir dış çember, iki konik yanak ve DIN 912 normlarına uygun bağlantı elemanlarından oluşmaktadır.

Yüksek tork gerektiren yerlerde uygulanması önerilir.

H8-h8 Tolerans - $R_t \leq 16 \mu\text{m}$



SELF-CENTERING

It is suitable for high torques and is self-centering.

Recommended for applications that requires high transmission values and excellent centering capabilities such as belt drums.

H8-h8 Tolerance - $R_t \leq 16 \mu\text{m}$

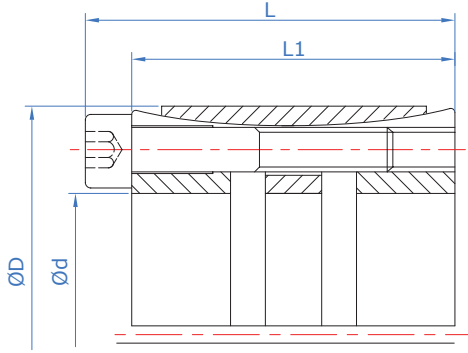

400 Plus Teknik Özellikler / Technical Properties

Ma	Vida sıkma döndürme momenti / Screw tightening torque
Mt	Maksimum aktarılabilen döndürme momenti (Fass=0 kN) / Transmissible torque moment
Fass	Maksimum aktarılabilen aksel yük (Mt=0 Nm) / Transmissible axial load
Ps	Mile temas basıncı / Shaft pressure
Ph	Göbek çapına temas basıncı / Hub pressure

Sipariş Kodu / Code	Ölçüler / Dimensions				Bağlantı elemanları / Tightening screws		Başarımlar / Performances					Ağırlık / Weight kg
	d	D	L1	L	DIN 912		Ma	Mt	Fass	Ps	Ph	
	mm	mm	mm	mm	Ad.	12.9 TİP	Nm	Nm	kN	N/mm ²	N/mm ²	
400 Plus - 100	100	145	72	84	10	M12	145	19.400	388	215	148	4,10
400 Plus - 110	110	155	72	84	10	M12	145	21.400	388	195	138	4,40
400 Plus - 120	120	165	72	84	11	M12	145	25.600	427	197	143	4,80
400 Plus - 130	130	180	82	94	14	M12	145	33.500	544	205	148	6,30
400 Plus - 140	140	190	82	94	15	M12	145	40.800	582	204	151	6,60
400 Plus - 150	150	200	82	94	15	M12	145	43.700	582	191	143	7,80
400 Plus - 160	160	210	82	94	16	M12	145	49.700	621	191	145	7,40
400 Plus - 170	170	225	93	107	15	M14	230	67.500	795	194	146	10,70
400 Plus - 180	180	235	93	107	15	M14	230	71.500	795	183	140	11,30
400 Plus - 190	190	250	105	119	16	M14	230	80.500	848	156	118	14,60
400 Plus - 200	200	260	105	119	18	M14	230	95.300	950	166	128	15,30
400 Plus - 220	220	285	111	127	15	M16	355	119.000	1.080	159	123	20,20
400 Plus - 240	240	305	111	127	20	M16	355	173.000	1.440	194	153	21,80
400 Plus - 260	260	325	111	127	21	M16	355	196.800	1.510	188	151	23,40
400 Plus - 280	280	355	111	131	15	M20	690	237.300	1.690	211	167	30,00
400 Plus - 300	300	375	111	131	15	M20	690	254.200	1.690	197	158	31,20
400 Plus - 320	320	405	136	156	20	M20	690	361.500	2.260	195	154	48,00
400 Plus - 340	340	425	136	156	20	M20	690	384.100	2.260	184	147	51,00
400 Plus - 360	360	455	160	182	20	M22	930	498.700	2.770	170	135	69,00
400 Plus - 380	380	475	160	182	22	M22	930	526.400	2.770	161	129	73,00
400 Plus - 400	400	495	160	182	24	M22	930	609.500	3.050	168	136	76,00
400 Plus - 420	420	515	160	182	24	M22	930	698.200	3.320	175	143	80,00
400 Plus - 440	440	535	160	182	24	M22	930	731.400	3.320	167	137	81,00
400 Plus - 460	460	555	160	182	24	M22	930	764.700	3.320	160	132	85,00
400 Plus - 480	480	575	160	182	25	M22	930	831.200	3.460	159	133	88,00
400 Plus - 500	500	595	160	182	25	M22	930	866.000	3.460	153	129	91,00
400 Plus - 520	520	615	160	182	28	M22	930	1.008.000	3.880	165	139	95,00
400 Plus - 540	540	635	160	182	28	M22	930	1.047.000	3.880	159	135	98,00
400 Plus - 560	560	655	160	182	30	M22	930	1.164.000	4.160	164	140	101,00
400 Plus - 580	580	675	160	182	30	M22	930	1.205.000	4.160	158	136	104,00
400 Plus - 600	600	695	160	182	30	M22	930	1.247.000	4.160	153	132	108,00



401 Plus



KENDİLİĞİNDEN YATAKLAYAN

401 Plus ; bir dış çember, iki konik yanak ve DIN 912 normlarına uygun bağlantı elemanlarından oluşmaktadır.

Çok yüksek tork gerektiren yerlerde uygulanması önerilir.

H8-h8 Tolerans - $Rt \leq 16 \mu m$



SELF-CENTERING

It is suitable for very high torques and is self-centering.

Recommended for applications that requires high transmission values and excellent centering capabilities such as belt drums.

H8-h8 Tolerance - $Rt \leq 16 \mu m$

401 Plus Teknik Özellikler / Technical Properties

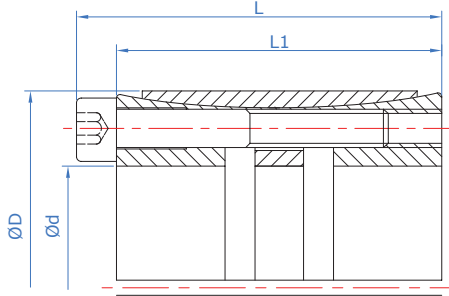

Ma	Vida sıkma döndürme momenti / Screw tightening torque
Mt	Maksimum aktarılabilen döndürme momenti (Fass=0 kN) / Transmissible torque moment
Fass	Maksimum aktarılabilen eksenel yük (Mt=0 Nm) / Transmissible axial load
Ps	Mile temas basıncı / Shaft pressure
Ph	Göbek çapına temas basıncı / Hub pressure

Sipariş Kodu / Code	Ölçüler / Dimensions				Bağlantı elemanları / Tightening screws		Başarımlar / Performances					Ağırlık / Weight kg
	d	D	L1	L	DIN 912		Ma	Mt	Fass	Ps	Ph	
	mm	mm	mm	mm	Ad.	12.9 TİP	Nm	Nm	kN	N/mm ²	N/mm ²	
401 Plus - 100	100	145	102	114	11	M12	145	27.700	555	210	145	6,00
401 Plus - 110	110	155	102	114	12	M12	145	33.300	605	209	148	6,20
401 Plus - 120	120	165	102	114	14	M12	145	42.400	706	223	162	7,20
401 Plus - 130	130	180	116	130	12	M14	230	53.700	826	201	145	10,00
401 Plus - 140	140	190	116	130	14	M14	230	67.400	963	217	160	10,20
401 Plus - 150	150	200	116	130	15	M14	230	77.400	1.030	217	163	10,80
401 Plus - 160	160	210	116	130	16	M14	230	88.100	1.100	217	166	11,50
401 Plus - 170	170	225	149	165	14	M16	355	111.500	1.310	186	141	17,00
401 Plus - 180	180	235	149	165	15	M16	355	126.500	1.410	188	144	18,50
401 Plus - 190	190	250	149	165	16	M16	355	142.400	1.500	190	145	21,50
401 Plus - 200	200	260	149	165	16	M16	355	149.900	1.500	181	139	22,00
401 Plus - 220	220	285	150	166	18	M16	355	185.500	1.690	185	143	26,59
401 Plus - 240	240	305	150	166	20	M16	355	224.800	1.870	188	148	28,70
401 Plus - 260	260	325	150	166	21	M16	690	255.700	1.970	182	146	31,23
401 Plus - 280	280	355	177	197	18	M20	690	369.900	2.640	190	150	46,77
401 Plus - 300	300	375	177	197	20	M20	690	440.300	2.940	197	157	49,00



550 Plus



UTL Plus ŞİRİNK DİSK

550 Plus ; iki konik parça ve DIN 931 normlarına uygun bağlantı elemanlarından oluşmaktadır.

Orta ve yüksek tork gerektiren yerlerde uygulanması önerilir.

h8 Tolerans - $R_t \leq 16 \mu\text{m}$

UTL Plus SHRINK DISCS

550 Plus are shrink discs for external, series "550", are characterised by a single tapered ring instead of opposite tapers of the 3 pieces shrink discs UTL series "600-601-602". The 550 Plus Shrink discs offer a better concentricity and centering and very good balancing. These features make the series highly suitable for mid-high speed applications.

h8 Tolerance - $R_t \leq 16 \mu\text{m}$

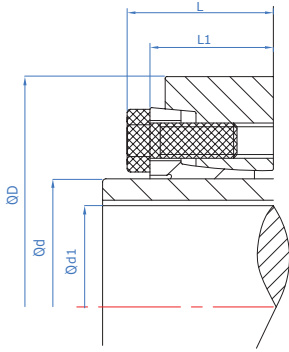

550 Plus Teknik Özellikler / Technical Properties

Ma	Vida sıkma döndürme momenti / Screw tightening torque
Mt	Maksimum aktarılabilen döndürme momenti (Fass=0 kN) / Transmissible torque moment
Fass	Maksimum aktarılabilen aksel yük (Mt=0 Nm) / Transmissible axial load
Ps	Kovan miline temas basıncı / Hollow shaft pressure

Sipariş Kodu / Code	Ölçüler / Dimensions					Bağlantı elemanları / Tightening screws		Başarımlar / Performances			Ağırlık / Weight kg
	d1	d	D	L1	L	DIN 931		Ma	Mt	Fass	
	mm	mm	mm	mm	mm	Ad.	10.9 TİP	Nm	Nm	kN	
550 Plus - 24	19	24	50	18	22	4	M6	12	160	17	0,2
	20								210	20	
	22								280	25	
550 Plus - 30	24	30	60	20	24	6	M6	12	270	23	0,3
	25								320	25	
	26								360	28	
550 Plus - 36	27	36	72	22	27,5	5	M8	30	440	32	0,5
	30								610	41	
	33								820	50	
550 Plus - 44	34	44	80	24	29,5	5	M8	30	690	41	0,6
	35								770	44	
	37								920	50	
550 Plus - 50	38	50	90	26	31,5	7	M8	30	1.110	58	0,8
	40								1.290	65	
	42								1.510	71	
550 Plus - 55	42	55	100	29	34,5	8	M8	30	1.230	59	1,1
	45								1.530	68	
	48								1.860	78	
550 Plus - 62	48	62	110	29	34,5	8	M8	30	1.670	70	1,3
	50								1.890	76	
	52								2.120	81	
550 Plus - 68	50	68	115	29	34,5	9	M8	30	1.870	75	1,3
	55								2.450	89	
	60								3.120	104	
550 Plus - 75	55	75	138	31	38	8	M10	59	2.330	85	2,3
	60								3.020	101	
	65								3.810	117	
550 Plus - 80	60	80	141	31	38	8	M10	59	3.190	106	2,3
	65								4.060	123	
	70								4.910	140	
550 Plus - 90	65	90	155	38	45	10	M10	59	5.400	166	3,2
	70								6.500	187	
	75								7.800	208	
550 Plus - 100	70	100	170	43	50	12	M10	59	6.000	171	4,3
	75								7.200	192	
	80								8.500	213	
550 Plus - 110	80	110	185	49	57	10	M12	100	10.000	249	5,8
	85								11.700	275	
	90								13.600	302	
550 Plus - 120	85	120	197	53	61	12	M12	100	11.900	280	6,9
	90								13.800	307	
	95								15.900	334	

Daha büyük çaplı UTL Konik Kilit ihtiyaçlarınız için bizi arayınız. / For assemblies requiring larger dimensions, contact our technical department.



600 Plus



UTL Plus ŞİRİNK DİSK

600-601-602 Plus ; iki konik yanak, bir iç çember ve DIN 931 normlarına uygun bağlantı elemanlarından oluşmaktadır.

Düşük tork gerektiren yerlerde (UTL 600) , yüksek tork gerektiren yerlerde (UTL 601), orta ve yüksek tork gerektiren yerlerde (UTL 602) uygulanması önerilir.

h8 Tolerans - $R_t \leq 16 \mu\text{m}$

UTL Plus SHRINK DISCS

600-601-602 Plus are external locking devices which are installed over hub projections. By locking the screws, radial pressures act on the hub allowing an effective and solid connection. Recommended for low, medium and high torque.

h8 Tolerance - $R_t \leq 16 \mu\text{m}$

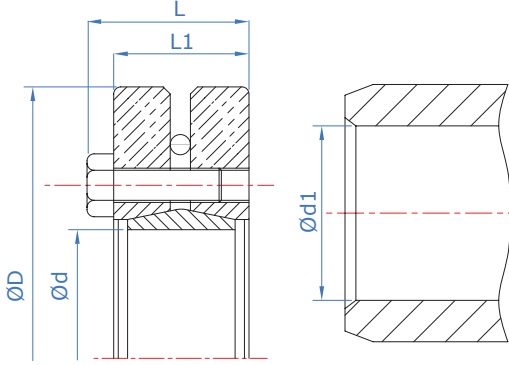

600 Plus Teknik Özellikler / Technical Properties

Ma	Vida sıkma döndürme momenti / Screw tightening torque
Mt	Maksimum aktarılabilen döndürme momenti (Fass=0 kN) / Transmissible torque moment
Fass	Maksimum aktarılabilen aksel yük (Mt=0 Nm) / Transmissible axial load
Ps	Kovan miline temas basıncı / Hollow shaft pressure

Sipariş Kodu / Code	Ölçüler / Dimensions					Bağlantı elemanları / Tightening screws		Başarımlar / Performances				Ağırlık / Weight kg		
	d1	d	D	L1	L	DIN 931		Ma	Mt	Fass	Ps			
	mm	mm	mm	mm	mm	Ad.	10.9 TİP	Nm	Nm	kN	N/mm²			
600 Plus - 24	19	24	50	18	22	6	M5	4	200	21	151	0,20		
	20								250				25	176
	21								310				30	202
600 Plus - 30	24	30	60	20	24	7	M5	4	310	26	127	0,30		
	25								370				30	144
	26								440				34	160
600 Plus - 36	28	36	72	22	26	5	M6	12	720	51	188	0,40		
	30								910				61	214
	31								940				60	210
600 Plus - 44	34	44	80	24	28	7	M6	12	1 160	68	180	0,60		
	35								1 290				73	192
	36								1 420				79	204
600 Plus - 50	38	50	90	26	30	8	M6	12	1 440	75	161	0,80		
	40								1 730				86	179
	42								2 050				97	199
600 Plus - 55	42	55	100	29	33	8	M6	12	1 580	75	137	1,10		
	45								2 030				90	160
	48								2 550				100	184
600 Plus - 62	48	62	110	29	33	10	M6	12	2 550	100	167	1,30		
	50								2 910				110	181
	52								3 090				110	182
600 Plus - 68	50	68	115	29	33	10	M6	12	2 350	90	135	1,4		
	55								2 970				100	151
	60								4 060				130	185
600 Plus - 75	55	75	138	31	36,5	7	M8	30	3 370	120	147	1,7		
	60								4 540				150	176
	65								5 880				180	206
600 Plus - 80	60	80	145	31	36,5	7	M8	30	3 890	120	142	1,9		
	65								5 100				150	168
	70								6 470				180	196
600 Plus - 85	60	85	155	38	43,5	10	M8	30	5 180	170	156	3,5		
	65								6 690				200	180
	70								8 400				240	205
600 Plus - 90	65	90	155	38	43,5	10	M8	30	5 910	180	152	3,3		
	70								7 470				210	174
	75								9 200				240	196
600 Plus - 95	65	95	170	43	48,5	12	M8	30	6 400	190	144	3,8		
	70								8 100				230	164
	75								10 000				260	184
600 Plus - 100	70	100	170	43	48,5	12	M8	30	7 300	200	141	4,7		
	75								9 000				240	158
	80								11 000				270	177

Daha büyük çaplı UTL Konik Kilit ihtiyaçlarınız için bizi arayınız. / For assemblies requiring larger dimensions, contact our technical department.



601 Plus



UTL Plus ŞİRİNK DİSK

600-601-602 Plus ; iki konik yanak, bir iç çember ve DIN 931 normlarına uygun bağlantı elemanlarından oluşmaktadır.

Düşük tork gerektiren yerlerde (UTL 600) , yüksek tork gerektiren yerlerde (UTL 601), orta ve yüksek tork gerektiren yerlerde (UTL 602) uygulanması önerilir.

h8 Tolerans - $R_t \leq 16 \mu\text{m}$

UTL Plus SHRINK DISCS

600-601-602 Plus are external locking devices which are installed over hub projections. By locking the screws, radial pressures act on the hub allowing an effective and solid connection. Recommended for low, medium and high torque.

h8 Tolerance - $R_t \leq 16 \mu\text{m}$

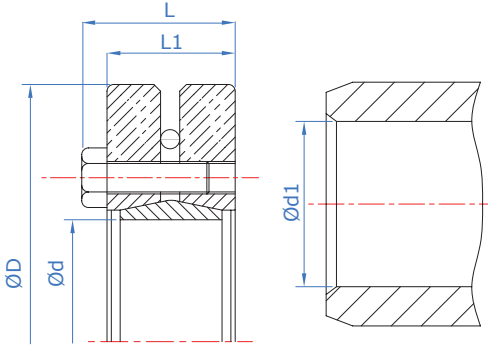

601 Plus Teknik Özellikler / Technical Properties

Ma	Vida sıkma döndürme momenti / Screw tightening torque
Mt	Maksimum aktarılabilen döndürme momenti (Fass=0 kN) / Transmissible torque moment
Fass	Maksimum aktarılabilen eksenel yük (Mt=0 Nm) / Transmissible axial load
Ps	Kovan miline temas basıncı / Hollow shaft pressure

Sipariş Kodu / Code	Ölçüler / Dimensions					Bağlantı elemanları / Tightening screws		Başarımlar / Performances				Ağırlık / Weight kg
	d1	d	D	L1	L	DIN 931		Ma	Mt	Fass	Ps	
	mm	mm	mm	mm	mm	Ad.	10.9 TİP	Nm	Nm	kN	N/mm ²	
601 Plus - 125	85	125	215	66	74	12	M12	100	18.700	442	161	11
	90								22.500	500	177	
	95								26.600	560	193	
601 Plus - 140	95	140	230	74	82	12	M12	100	19.800	417	122	13
	100								23.500	472	134	
	105								27.600	527	146	
601 Plus - 155	105	155	263	80	88	15	M12	100	29.000	553	133	20
	110								33.600	612	143	
	115								38.500	671	154	
601 Plus - 165	115	165	290	88	98	10	M16	250	45.800	800	163	26
	120								51.900	870	173	
	125								58.300	930	183	
601 Plus - 175	125	175	300	88	98	10	M16	250	52.200	840	157	29
	130								58.500	900	166	
	135								65.100	970	175	
601 Plus - 185	135	185	330	112	122	15	M16	250	89.400	1330	189	47
	140								99.000	1410	198	
	145								109.100	1510	207	
601 Plus - 200	145	200	350	112	122	15	M16	250	94.900	1310	171	50
	150								104.400	1390	179	
	155								114.300	1480	186	
601 Plus - 220	160	220	370	134	144	20	M16	250	142.900	1790	175	65
	165								155.500	1890	181	
	170								168.600	1980	187	
601 Plus - 240	170	240	405	144	159	15	M20	490	174.500	2050	176	87
	180								203.100	2260	188	
	190								234.100	2460	199	
601 Plus - 260	190	260	430	160	175	18	M20	490	244.600	2580	178	100
	200								280.500	2810	189	
	210								319.000	3040	199	
601 Plus - 280	210	280	460	172	187	20	M20	490	315.000	3000	175	132
	220								356.100	3240	184	
	230								400.000	3480	193	
601 Plus - 300	230	300	485	176	191	20	M20	490	356.100	3100	161	140
	240								395.600	3320	169	
	250								420.800	3440	173	



602 Plus



UTL Plus ŞİRİNK DİSK

600-601-602 Plus ; iki konik yanak, bir iç çember ve DIN 931 normlarına uygun bağlantı elemanlarından oluşmaktadır.

Düşük tork gerektiren yerlerde (600 Plus) , yüksek tork gerektiren yerlerde (601 Plus), orta ve yüksek tork gerektiren yerlerde (602 Plus) uygulanması önerilir.

h8 Tolerans - $R_t \leq 16 \mu\text{m}$



UTL Plus SHRINK DISCS

600-601-602 Plus are external locking devices which are installed over hub projections. By locking the screws, radial pressures act on the hub allowing an effective and solid connection. Recommended for low, medium and high torque.

h8 Tolerance - $R_t \leq 16 \mu\text{m}$

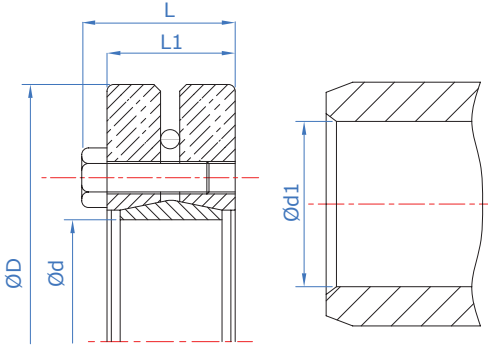

602 Plus Teknik Özellikler / Technical Properties

Ma	Vida sıkma döndürme momenti / Screw tightening torque
Mt	Maksimum aktarılabilen döndürme momenti (Fass=0 kN) / Transmissible torque moment
Fass	Maksimum aktarılabilen aksel yük (Mt=0 Nm) / Transmissible axial load
Ps	Kovan miline temas basıncı / Hollow shaft pressure

Sipariş Kodu / Code	Ölçüler / Dimensions					Bağlantı elemanları / Tightening screws		Başarımlar / Performances				Ağırlık / Weight kg
	d1	d	D	L1	L	DIN 931		Ma	Mt	Fass	Ps	
	mm	mm	mm	mm	mm	Ad.	10.9 TİP	Nm	Nm	kN	N/mm ²	
602 Plus - 125	85	125	190	52	59	8	M10	59	10.600	225	99	6
	90								12.800	258	111	
	95								15.300	292	125	
602 Plus - 140	95	140	220	52	59	10	M10	59	18.200	331	126	8
	100								23.900	399	149	
	105								26.700	428	160	
602 Plus - 155	105	155	245	52	59	12	M10	59	30.100	464	154	10
	110								33.700	500	166	
	115								37.600	537	179	
602 Plus - 165	115	165	260	62	70	10	M12	100	36.300	539	149	14
	120								40.500	579	159	
	125								44.800	619	170	
602 Plus - 175	125	175	275	62	70	10	M12	100	40.000	552	142	16
	130								44.200	590	152	
	135								48.700	629	162	
602 Plus - 185	135	185	295	62	70	12	M12	100	53.900	697	168	20
	140								58.900	737	177	
	145								64.100	777	188	
602 Plus - 195	145	195	315	72	80	15	M12	100	73.300	889	171	27
	150								79.500	936	180	
	155								86.100	984	189	
602 Plus - 220	160	220	345	84	94	10	M16	250	99.800	1.109	185	35
	165								111.800	1.177	171	
	170								128.600	1.287	186	
602 Plus - 240	170	240	370	84	94	12	M16	250	135.700	1.357	179	44
	180								154.200	1.469	193	
	190								164.000	1.526	201	
602 Plus - 260	190	260	395	92	102	12	M16	250	153.000	1.392	167	48
	200								170.400	1.482	161	
	210								180.500	1.536	167	
602 Plus - 280	210	280	425	104	114	16	M16	250	207.300	1.803	180	60
	220								228.300	1.903	171	
	230								253.600	2.030	181	
602 Plus - 300	230	300	460	104	114	18	M16	250	258.900	2.071	172	75
	240								283.700	2.183	181	
	250								312.500	2.315	192	

UTL®

Paslanmaz Konik Kilitler Locking Assemblies Stainless Steel



UTL - 100P



KENDİLİĞİNDEN YATAKLAYAN

UTL - 100P ; iki konik parça, bir çember ve DIN 912 normlarına uygun bağlantı elemanlarından oluşmaktadır.

Orta ve yüksek tork gerektiren yerlerde ve küçük çaplı uygulamalarda önerilir.

H8-h8 Tolerans - $R_t \leq 16 \mu\text{m}$



SELF-CENTERING

Locking assembly with single taper design. Consists of two tapered rings and a spacer. It has minimum overall dimensions in virtue of the reduced thickness of the cones. UTL-100P is suitable for the applications where small hubs are requested. It is recommended for mid-high torques and is self centering.

H8-h8 Tolerance - $R_t \leq 16 \mu\text{m}$

www.utl.com.tr

www.utllockingassemblies.com

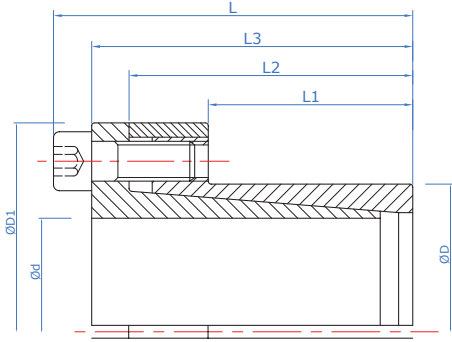

UTL - 100P Teknik Özellikler / Technical Properties

Ma	Vida sıkma döndürme momenti / Screw tightening torque
Mt	Maksimum aktarılabilen döndürme momenti (Fass=0 kN) / Transmissible torque moment
Fass	Maksimum aktarılabilen eksenel yük (Mt=0 Nm) / Transmissible axial load
Ps	Mile temas basıncı / Shaft pressure
Ph	Göbek çapına temas basıncı / Hub pressure

Sipariş Kodu / Code	Ölçüler / Dimensions							Bağlantı elemanları / Tightening screws		Başarımlar / Performances					Ağırlık / Weight kg
	d	D	L1	L2	L3	L	D1	DIN 912		Ma	Mt	Fass	Ps	Ph	
	mm	mm	mm	mm	mm	mm	mm	Ad.	12.9 TİP	Nm	Nm	kN	N/mm ²	N/mm ²	
UTL 100P - 6	6	14	10	18,5	21	24	25	3	M3	2	12	4	185	80	0,04
UTL 100P - 7	7	15	12	22	25	29	27	3	M4	5	25	7	235	110	0,06
UTL 100P - 8	8	15	12	22	25	29	27	3	M4	5	29	7	205	110	0,05
UTL 100P - 9	9	16	14	23	26	30	28	4	M4	5	44	10	205	115	0,06
UTL 100P - 10	10	16	14	23	26	30	28	4	M4	5	49	10	185	115	0,06
UTL 100P - 11	11	18	14	23	26	30	32	4	M4	5	53	10	170	105	0,07
UTL 100P - 12	12	18	14	23	26	30	32	4	M4	5	58	10	160	105	0,07
UTL 100P - 13	13	23	14	23	26	30	38	4	M4	5	63	10	140	80	0,11
UTL 100P - 14	14	23	14	23	26	30	38	4	M4	5	68	10	130	80	0,1
UTL 100P - 15	15	24	16	29	36	42	45	3	M6	17	127	17	185	115	0,22
UTL 100P - 16	16	24	16	29	36	42	45	3	M6	17	136	17	175	115	0,22
UTL 100P - 17	17	26	18	31	38	44	47	4	M6	17	180	22	190	125	0,25
UTL 100P - 18	18	26	18	31	38	44	47	4	M6	17	200	22	180	125	0,24
UTL 100P - 19	19	27	18	31	38	44	49	4	M6	17	210	22	170	120	0,26
UTL 100P - 20	20	28	18	31	38	44	50	4	M6	17	220	22	160	115	0,27
UTL 100P - 22	22	32	25	38	45	51	54	4	M6	17	250	22	115	80	0,34
UTL 100P - 24	24	34	25	38	45	51	56	4	M6	17	270	22	105	75	0,36
UTL 100P - 25	25	34	25	38	45	51	56	4	M6	17	280	22	100	75	0,35
UTL 100P - 28	28	39	25	38	45	51	61	6	M6	17	465	33	135	97	0,48
UTL 100P - 30	30	41	25	38	45	51	62	6	M6	17	510	33	127	90	0,48
UTL 100P - 32	32	43	25	38	45	51	65	6	M6	17	540	33	120	90	0,47
UTL 100P - 35	35	47	32	45	52	58	69	6	M6	17	790	45	105	80	0,58
UTL 100P - 38	38	50	32	45	52	58	72	8	M6	17	860	45	100	75	0,61
UTL 100P - 40	40	53	32	45	52	58	75	8	M6	17	900	45	95	70	0,68
UTL 100P - 42	42	55	35	45	52	58	78	8	M6	17	950	45	90	70	0,76
UTL 100P - 45	45	59	45	62	70	78	86	8	M8	41	1.890	84	110	85	1,2
UTL 100P - 48	48	62	45	62	70	78	87	8	M8	41	2.010	84	105	80	1,2
UTL 100P - 50	50	65	45	62	70	78	92	8	M8	41	2.100	84	100	75	1,4
UTL 100P - 55	55	71	55	72	80	88	98	9	M8	41	2.600	94	85	65	1,6
UTL 100P - 60	60	77	55	72	80	88	104	9	M8	41	2.840	94	75	60	1,8

UTL®

Paslanmaz Konik Kilitler Locking Assemblies Stainless Steel



UTL - 200P



KENDİLİĞİNDEN YATAKLAMAYAN

UTL - 200P ; dış ve iç çember, iki konik yanak ve DIN 912 normlarına uygun bağlantı elemanlarından oluşmaktadır.

Orta ve yüksek tork gerektiren yerlerde, çok amaçlı olarak uygulanması önerilir.

H8-h8 Tolerans - $R_t \leq 16 \mu m$



NOT SELF-CENTERING

UTL - 200P locking assembly unit consists of four pieces with two inside double-cone rings joined through a set of tightening screws.

It is recommended for medium torques. Although it is not self centering, it can be easily assembled and disassembled.

H8-h8 Tolerance - $R_t \leq 16 \mu m$

www.utl.com.tr

www.utllockingassemblies.com

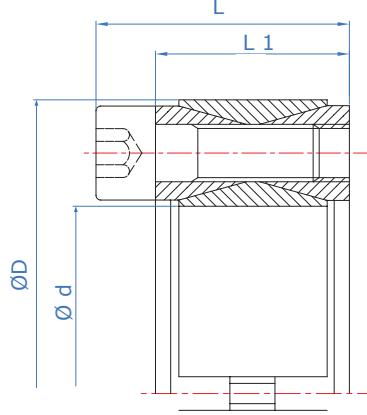

UTL - 200P Teknik Özellikler / Technical Properties

Ma	Vida sıkma döndürme momenti / Screw tightening torque
Mt	Maksimum aktarılabilen döndürme momenti (Fass=0 kN) / Transmissible torque moment
Fass	Maksimum aktarılabilen eksenel yük (Mt=0 Nm) / Transmissible axial load
Ps	Mile temas basıncı / Shaft pressure
Ph	Göbek çapına temas basıncı / Hub pressure

Sipariş Kodu / Code	Ölçüler / Dimensions				Bağlantı elemanları / Tightening screws		Başarımlar / Performances					Ağırlık / Weight kg
	d	D	L1	L	DIN 912		Ma	Mt	Fass	Ps	Ph	
	mm	mm	mm	mm	Ad.	12.9 TİP	Nm	Nm	kN	N/mm ²	N/mm ²	
UTL 200P - 18	18	47	20	27	8	M6	15	260	29	225	95	0,2
UTL 200P - 19	19	47	20	27	8	M6	15	270	29	225	95	0,2
UTL 200P - 20	20	47	20	27	8	M6	15	280	29	225	95	0,3
UTL 200P - 22	22	47	20	27	8	M6	15	310	29	210	95	0,3
UTL 200P - 24	24	50	20	27	8	M6	15	370	32	210	100	0,3
UTL 200P - 25	25	50	20	27	8	M6	15	400	32	200	100	0,3
UTL 200P - 28	28	55	20	27	10	M6	15	500	36	200	100	0,3
UTL 200P - 30	30	55	20	27	10	M6	15	530	36	185	100	0,3
UTL 200P - 32	32	60	20	27	12	M6	15	680	42	205	110	0,3
UTL 200P - 35	35	60	20	27	12	M6	15	750	43	190	110	0,3
UTL 200P - 38	38	65	20	27	14	M6	15	930	49	200	115	0,4
UTL 200P - 40	40	65	20	27	14	M6	15	980	49	190	115	0,3
UTL 200P - 42	42	75	24	33	12	M8	37	1.580	75	235	130	0,6
UTL 200P - 45	45	75	24	33	12	M8	37	1.700	76	220	130	0,6
UTL 200P - 48	48	80	24	33	12	M8	37	1.790	74	210	120	0,6
UTL 200P - 50	50	80	24	33	12	M8	37	1.870	75	200	120	0,6
UTL 200P - 55	55	85	24	33	14	M8	37	2.390	88	210	135	0,6
UTL 200P - 60	60	90	24	33	14	M8	37	2.610	88	190	125	0,7
UTL 200P - 65	65	95	24	33	16	M8	37	3.210	98	200	135	0,7
UTL 200P - 70	70	110	28	39	14	M10	70	4.600	132	210	130	1,3
UTL 200P - 75	75	115	28	39	14	M10	70	4.900	131	195	125	1,3
UTL 200P - 80	80	120	28	39	14	M10	70	5.200	131	180	120	1,4
UTL 200P - 85	85	125	28	39	16	M10	70	6.300	148	195	130	1,4

UTL®

Paslanmaz Konik Kilitler Locking Assemblies Stainless Steel

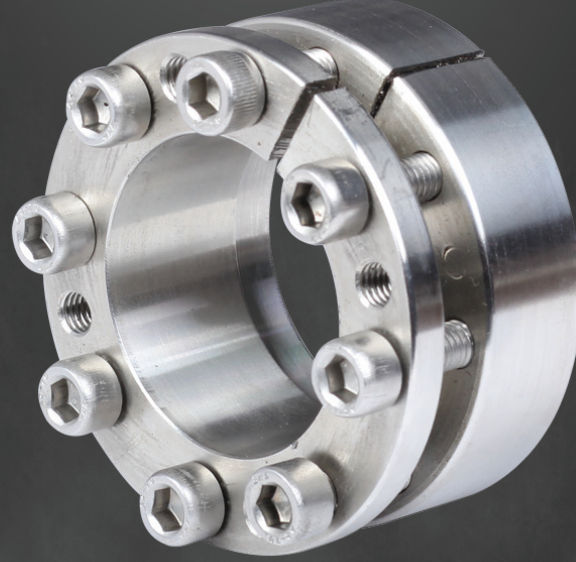

UTL - 300P



KENDİLİĞİNDEN YATAKLAYAN

UTL - 300P ; iki konik parça ve DIN 912 normlarına uygun bağlantı elemanlarından oluşmaktadır.

Orta tork gerektiren yerlerde uygulanması önerilir.

H8-h8 Tolerans - $R_t \leq 16 \mu m$



SELF-CENTERING

Locking assembly with single taper design. Provides good concentricity and is self centering. A small axial movement of the hub during the installation operation may occur. Applications requiring accurate axial positioning are not recommended with this type of locking assembly. UTL-300P is suitable for applications with medium torques.

H8-h8 Tolerance - $R_t \leq 16 \mu m$

www.utl.com.tr

www.utllockingassemblies.com

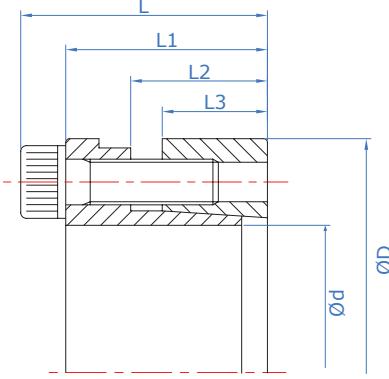

UTL - 300P Teknik Özellikler / Technical Properties

Ma	Vida sıkma döndürme momenti / Screw tightening torque
Mt	Maksimum aktarılabilen döndürme momenti (Fass=0 kN) / Transmissible torque moment
Fass	Maksimum aktarılabilen eksenel yük (Mt=0 Nm) / Transmissible axial load
Ps	Mile temas basıncı / Shaft pressure
Ph	Göbek çapına temas basıncı / Hub pressure

Sipariş Kodu / Code	Ölçüler / Dimensions						Bağlantı elemanları / Tightening screws		Başarımlar / Performances					Ağırlık / Weight kg
	d	D	L3	L2	L1	L	DIN 912		Ma	Mt	Fass	Ps	Ph	
	mm	mm	mm	mm	mm	mm	Ad.	12.9 TİP	Nm	Nm	kN	N/mm ²	N/mm ²	
UTL 300P - 20	20	47	17	22	28	34	5	M6	14	380	38	295	125	0,3
UTL 300P - 22	22	47	17	22	28	34	5	M6	14	410	38	270	125	0,3
UTL 300P - 24	24	50	17	22	28	34	6	M6	14	450	38	245	120	0,3
UTL 300P - 25	25	50	17	22	28	34	6	M6	14	570	46	285	140	0,3
UTL 300P - 28	28	55	17	22	28	34	6	M6	14	630	46	255	130	0,4
UTL 300P - 30	30	55	17	22	28	34	6	M6	14	660	46	235	130	0,3
UTL 300P - 32	32	60	17	22	28	34	8	M6	14	970	60	295	155	0,4
UTL 300P - 35	35	60	17	22	28	34	8	M6	14	1.060	60	270	155	0,4
UTL 300P - 38	38	65	17	22	28	34	8	M6	14	1.150	60	250	145	0,4
UTL 300P - 40	40	65	17	22	28	34	8	M6	14	1.210	60	235	145	0,4
UTL 300P - 42	42	75	20	25	33	41	7	M8	35	2.050	98	300	170	0,8
UTL 300P - 45	45	75	20	25	33	41	7	M8	35	2.200	98	290	170	0,6
UTL 300P - 48	48	80	20	25	33	41	7	M8	35	2.350	98	270	160	0,8
UTL 300P - 50	50	80	20	25	33	41	7	M8	35	2.450	98	260	160	0,8
UTL 300P - 55	55	85	20	25	33	41	8	M8	35	3.080	112	270	175	0,8
UTL 300P - 60	60	90	20	25	33	41	8	M8	35	3.360	112	245	165	0,8
UTL 300P - 65	65	95	20	25	33	41	9	M8	35	4.090	126	255	175	0,9
UTL 300P - 70	70	110	24	30	40	50	8	M10	70	6.300	179	280	180	1,8
UTL 300P - 75	75	115	24	30	40	50	8	M10	70	6.700	179	260	170	1,8
UTL 300P - 80	80	120	24	30	40	50	8	M10	70	7.150	179	250	170	1,8
UTL 300P - 85	85	125	24	30	40	50	9	M10	70	8.500	200	260	180	2,0
UTL 300P - 90	90	130	24	30	40	50	9	M10	70	9.100	200	250	170	2,1
UTL 300P - 95	95	135	24	30	40	50	10	M10	70	10.600	224	260	180	2,1
UTL 300P - 100	100	145	26	32	44	56	8	M12	125	13.400	268	270	190	2,8

UTL®

Paslanmaz Konik Kilitler Locking Assemblies Stainless Steel



UTL - 301P



KENDİLİĞİNDEN YATAKLAYAN

UTL - 301P ; iki konik parça ve DIN 912 normlarına uygun bağlantı elemanlarından oluşmaktadır.

Yüksek tork gerektiren yerlerde uygulanması önerilir.

H8-h8 Tolerans - $R_t \leq 16 \mu\text{m}$

SELF-CENTERING

Locking assembly with single taper design. It is suitable for high torques. Provide good concentricity and self centering. A small axial movement of the hub during the installation operation may occur.

Applications in need of an accurate axial positioning are not recommended with this type of locking assembly.

H8-h8 Tolerance - $R_t \leq 16 \mu\text{m}$

www.utl.com.tr

www.utllockingassemblies.com

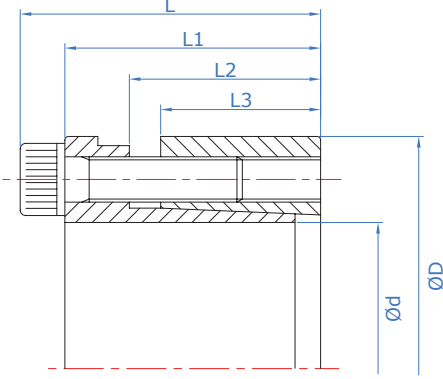

UTL - 301P Teknik Özellikler / Technical Properties

Ma	Vida sıkma döndürme momenti / Screw tightening torque
Mt	Maksimum aktarılabilen döndürme momenti (Fass=0 kN) / Transmissible torque moment
Fass	Maksimum aktarılabilen eksenel yük (Mt=0 Nm) / Transmissible axial load
Ps	Mile temas basıncı / Shaft pressure
Ph	Göbek çapına temas basıncı / Hub pressure

Sipariş Kodu / Code	Ölçüler / Dimensions						Bağlantı elemanları / Tightening screws		Başarımlar / Performances					Ağırlık / Weight kg
	d	D	L3	L2	L1	L	DIN 912		Ma	Mt	Fass	Ps	Ph	
	mm	mm	mm	mm	mm	mm	Ad.	12.9 TİP	Nm	Nm	kN	N/mm ²	N/mm ²	
UTL 301P - 20	20	47	26	30	41	47	6	M6	17	540	54	280	120	0,4
UTL 301P - 22	22	47	26	30	41	47	6	M6	17	600	54	255	120	0,4
UTL 301P - 24	24	50	26	30	41	47	6	M6	17	650	54	235	115	0,4
UTL 301P - 25	25	50	26	30	41	47	6	M6	17	680	54	225	115	0,4
UTL 301P - 28	28	55	26	30	41	47	6	M6	17	760	54	200	105	0,5
UTL 301P - 30	30	55	26	30	41	47	6	M6	17	820	54	185	105	0,5
UTL 301P - 32	32	60	26	30	41	47	8	M6	17	1.160	73	235	125	0,6
UTL 301P - 35	35	60	26	30	41	47	8	M6	17	1.270	73	215	125	0,5
UTL 301P - 38	38	65	26	30	41	47	8	M6	17	1.380	73	200	115	0,6
UTL 301P - 40	40	65	26	30	41	47	8	M6	17	1.450	73	190	115	0,6
UTL 301P - 42	42	75	30	35	49	57	6	M8	41	2.130	101	215	120	1
UTL 301P - 45	45	75	30	35	49	57	6	M8	41	2.280	101	200	120	1
UTL 301P - 48	48	80	30	35	49	57	6	M8	41	2.430	101	190	115	1,1
UTL 301P - 50	50	80	30	35	49	57	6	M8	41	2.530	101	180	115	1
UTL 301P - 55	55	85	30	35	49	57	8	M8	41	3.700	135	220	140	1,1
UTL 301P - 60	60	90	30	35	49	57	8	M8	41	4.000	135	200	135	1,2
UTL 301P - 65	65	95	30	35	49	57	8	M8	41	4.380	135	185	125	1,3
UTL 301P - 70	70	110	40	45	59	69	8	M10	83	7.500	214	205	130	2,2
UTL 301P - 75	75	115	40	45	59	69	8	M10	83	8.000	214	190	125	2,5
UTL 301P - 80	80	120	40	45	59	69	8	M10	83	8.560	214	180	120	2,6
UTL 301P - 85	85	125	40	45	59	69	10	M10	83	11.370	268	210	145	2,8
UTL 301P - 90	90	130	40	45	59	69	10	M10	83	12.000	268	200	135	2,7
UTL 301P - 95	95	135	40	45	59	69	10	M10	83	12.600	268	190	130	2,9
UTL 301P - 100	100	145	46	52	68	80	8	M12	145	15.580	312	180	125	3,9

UTL®

Paslanmaz Konik Kilitler Locking Assemblies Stainless Steel



UTL - 350FP



KENDİLİĞİNDEN YATAKLAYAN

UTL - 350FP ; iki konik parça, bir aksenal kaymayı önleyici sabit flanş ve DIN 912 normlarına uygun bağlantı elemanlarından oluşmaktadır.

Orta tork gerektiren yerlerde uygulanması önerilir.

H8-h8 Tolerans - $Rt \leq 16 \mu m$

SELF-CENTERING

Locking assembly with single taper design. Provides good concentricity and self centering. It is recommended for medium torques and is self-centering.

The flange design prevents axial movement during installation.

H8-h8 Tolerance - $Rt \leq 16 \mu m$

www.utl.com.tr

www.utllockingassemblies.com

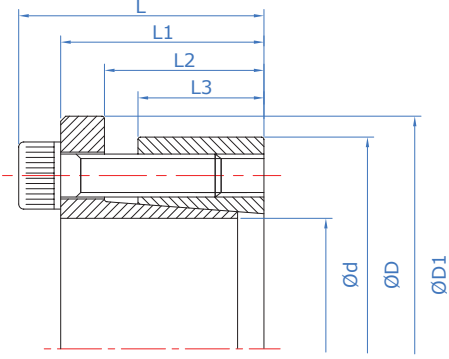

UTL - 350FP Teknik Özellikler / Technical Properties

Ma	Vida sıkma döndürme momenti / Screw tightening torque
Mt	Maksimum aktarılabilen döndürme momenti (Fass=0 kN) / Transmissible torque moment
Fass	Maksimum aktarılabilen aksel yük (Mt=0 Nm) / Transmissible axial load
Ps	Mile temas basıncı / Shaft pressure
Ph	Göbek çapına temas basıncı / Hub pressure

Sipariş Kodu / Code	Ölçüler / Dimensions							Bağlantı elemanları / Tightening screws		Başarımlar / Performances					Ağırlık / Weight kg
	d	D	D1	L3	L2	L1	L	DIN 912		Ma	Mt	Fass	Ps	Ph	
	mm	mm	mm	mm	mm	mm	mm	Ad.	12.9 TİP	Nm	Nm	kN	N/mm ²	N/mm ²	
UTL 350FP - 20	20	47	54	17	22	28	34	5	M6	17	280	28	220	95	0,3
UTL 350FP - 22	22	47	54	17	22	28	34	5	M6	17	300	28	200	95	0,3
UTL 350FP - 24	24	50	57	17	22	28	34	6	M6	17	330	28	180	90	0,3
UTL 350FP - 25	25	50	57	17	22	28	34	6	M6	17	420	34	210	105	0,3
UTL 350FP - 28	28	55	62	17	22	28	34	6	M6	17	470	34	190	95	0,4
UTL 350FP - 30	30	55	62	17	22	28	34	6	M6	17	500	34	175	95	0,4
UTL 350FP - 32	32	60	67	17	22	28	34	8	M6	17	720	45	220	115	0,4
UTL 350FP - 35	35	60	67	17	22	28	34	8	M6	17	790	45	200	115	0,4
UTL 350FP - 38	38	65	72	17	22	28	34	8	M6	17	850	45	185	105	0,5
UTL 350FP - 40	40	65	72	17	22	28	34	8	M6	17	900	45	175	105	0,5
UTL 350FP - 42	42	75	82	20	25	33	41	7	M8	41	1.530	73	225	125	0,8
UTL 350FP - 45	45	75	82	20	25	33	41	7	M8	41	1.650	73	215	125	0,7
UTL 350FP - 48	48	80	87	20	25	33	41	7	M8	41	1.760	73	200	120	0,8
UTL 350F - 50	50	80	87	20	25	33	41	7	M8	41	1.830	73	195	120	0,8
UTL 350FP - 55	55	85	92	20	25	33	41	8	M8	41	2.300	83	200	130	0,9
UTL 350FP - 60	60	90	97	20	25	33	41	8	M8	41	2.510	83	185	125	0,9
UTL 350FP - 65	65	95	102	20	25	33	41	9	M8	41	3.060	94	190	130	1
UTL 350FP - 70	70	110	117	24	30	40	50	8	M10	83	4.670	133	210	135	1,9
UTL 350FP - 75	75	115	122	24	30	40	50	8	M10	83	5.000	133	195	125	2
UTL 350FP - 80	80	120	127	24	30	40	50	8	M10	83	5.300	133	185	125	2
UTL 350FP - 85	85	125	132	24	30	40	50	9	M10	83	6.300	148	195	135	2
UTL 350FP - 90	90	130	137	24	30	40	50	9	M10	83	6.750	148	185	130	2,2
UTL 350FP - 95	95	135	142	24	30	40	50	10	M10	83	7.900	166	195	135	2,3
UTL 350FP - 100	100	145	152	26	32	44	56	8	M12	145	9.700	194	200	140	3

UTL®

Paslanmaz Konik Kilitler Locking Assemblies Stainless Steel



UTL - 351FP



KENDİLİĞİNDEN YATAKLAYAN

UTL - 351FP ; iki konik parça, bir aksenal kaymayı önleyici sabit flanş ve DIN 912 normlarına uygun bağlantı elemanlarından oluşmaktadır.

Yüksek tork gerektiren yerlerde uygulanması önerilir.

H8-h8 Tolerans - $Rt \leq 16 \mu m$

SELF-CENTERING

Locking assembly with single taper design. Provides good concentricity and self centering. It is recommended for high torques.

The flange design prevents axial movement during installation.

H8-h8 Tolerance - $Rt \leq 16 \mu m$

www.utl.com.tr

www.utllockingassemblies.com

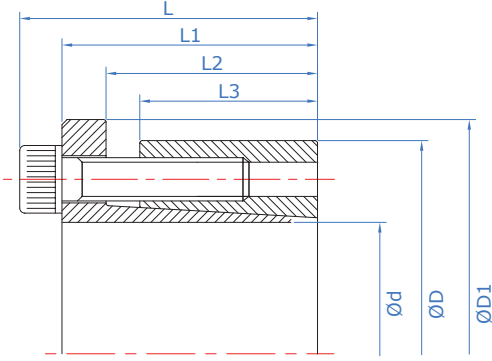

UTL - 351FP Teknik Özellikler / Technical Properties

Ma	Vida sıkma döndürme momenti / Screw tightening torque
Mt	Maksimum aktarılabilen döndürme momenti (Fass=0 kN) / Transmissible torque moment
Fass	Maksimum aktarılabilen eksenel yük (Mt=0 Nm) / Transmissible axial load
Ps	Mile temas basıncı / Shaft pressure
Ph	Göbek çapına temas basıncı / Hub pressure

Sipariş Kodu / Code	Ölçüler / Dimensions							Bağlantı elemanları / Tightening screws		Başarımlar / Performances					Ağırlık / Weight kg
	d	D	D1	L3	L2	L1	L	DIN 912		Ma	Mt	Fass	Ps	Ph	
	mm	mm	mm	mm	mm	mm	mm	Ad.	12.9 TİP	Nm	Nm	kN	N/mm ²	N/mm ²	
UTL 351FP - 20	20	47	53	26	30	42	48	6	M6	17	330	34	175	75	0,5
UTL 351FP - 22	22	47	53	26	30	42	48	6	M6	17	370	34	160	75	0,5
UTL 351FP - 24	24	50	56	26	31	43	49	6	M6	17	400	34	145	70	0,5
UTL 351FP - 25	25	50	56	26	31	43	49	6	M6	17	420	34	140	70	0,5
UTL 351FP - 28	28	55	61	26	31	43	49	6	M6	17	470	34	125	65	0,6
UTL 351FP - 30	30	55	61	26	31	43	49	6	M6	17	510	34	115	65	0,6
UTL 351FP - 32	32	60	66	26	31	43	49	8	M6	17	720	45	145	80	0,7
UTL 351FP - 35	35	60	66	26	31	43	49	8	M6	17	790	45	135	80	0,6
UTL 351FP - 38	38	65	71	26	31	43	49	8	M6	17	860	45	125	70	0,8
UTL 351FP - 40	40	65	71	26	31	43	49	8	M6	17	900	45	120	70	0,6
UTL 351FP - 42	42	75	81	30	36	51	59	6	M8	41	1.320	63	135	75	1,2
UTL 351FP - 45	45	75	81	30	36	51	59	6	M8	41	1.410	63	125	75	1,1
UTL 351FP - 48	48	80	86	30	36	51	59	6	M8	41	1.510	63	120	70	1,3
UTL 351FP - 50	50	80	86	30	36	51	59	6	M8	41	1.570	63	110	70	1,1
UTL 351FP - 55	55	85	91	30	36	51	59	8	M8	41	2.310	84	135	90	1,2
UTL 351FP - 60	60	90	96	30	36	51	59	8	M8	41	2.520	84	124	85	1,3
UTL 351FP - 65	65	95	102	30	36	51	59	8	M8	41	2.730	84	115	80	1,4
UTL 351FP - 70	70	110	117	40	46	59	69	8	M10	83	4.650	133	125	80	2,5
UTL 351FP - 75	75	115	122	40	46	59	69	8	M10	83	5.000	133	120	80	2,6
UTL 351FP - 80	80	120	127	40	46	59	69	8	M10	83	5.330	133	110	75	2,8
UTL 351FP - 85	85	125	132	40	46	59	69	10	M10	83	7.080	167	130	90	2,8
UTL 351FP - 90	90	130	137	40	46	59	69	10	M10	83	7.500	167	125	85	3
UTL 351FP - 95	95	135	142	40	46	59	69	10	M10	83	7.900	167	115	85	3
UTL 351FP - 100	100	145	153	46	52	70	82	8	M12	145	9.700	194	115	80	5,5



UTL - 150



KENDİLİĞİNDEN YATAKLAMAYAN

UTL - 150 ; bir iç ve bir dış konik bilezikten oluşmaktadır.

Düşük tork gerektiren yerlere uygulanması önerilir. Harici sıkma flanşı ile birlikte kullanmak için tasarlanmıştır.

Harici flanş kullanıcı tarafından tedarik edilir.

NOT SELF-CENTERING

Locking elements consist of one internal and one external tapered rings. They are designed to work in combination with a clamp flange which can be bolted on a hub or shaft depending on application need. The number of locking screws depends on the torque to be transmitted. UTL-150 requires very small axial installation dimensions.

Customer supplies pressure flange.

UTL - 150 Teknik Özellikler / Technical Properties

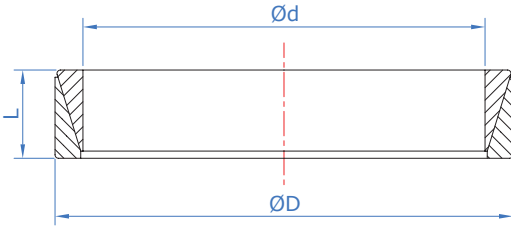

Mt	Maksimum aktarılabilen döndürme momenti (Fass=0 kN) / Transmissible torque moment
Fass	Maksimum aktarılabilen eksenel yük (Mt=0 Nm) / Transmissible axial load
Ps	Mile temas basıncı / Shaft pressure
Ph	Göbek çapına temas basıncı / Hub pressure
Pt	Birleşme gücü / Assembling load
Pa	Kilitleme gücü / Locking load

Sipariş Kodu / Code	Ölçüler / Dimensions			Başarımlar / Performances						Ağırlık / Weight kg
	d	D	L	Pt	Pa	Mt	Fass	Ps	Ph	
	mm	mm	mm	N	N	Nm	kN	N/mm ²	N/mm ²	
UTL 150 - 6	6	9	4,5	-	3800	2	0,84	115	75	0,002
UTL 150 - 7	7	10	4,5	-	3900	3	0,86	105	70	0,002
UTL 150 - 8	8	11	4,5	-	5300	5	1,17	120	90	0,002
UTL 150 - 9	9	12	4,5	7650	15600	8	1,76	140	105	0,002
UTL 150 - 10	10	13	4,5	7000	15600	10	1,91	135	105	0,002
UTL 150 - 12	12	15	4,5	7000	15600	11	1,9	115	90	0,002
UTL 150 - 13	13	16	4,5	6500	15600	13	2,02	110	90	0,004
UTL 150 - 14	14	18	6,3	11000	25400	22	3,18	115	90	0,005
UTL 150 - 15	15	19	6,3	10800	25400	24	3,24	110	85	0,005
UTL 150 - 16	16	20	6,3	10000	25400	27	3,42	105	85	0,006
UTL 150 - 17	17	21	6,3	9600	25400	30	3,51	105	85	0,006
UTL 150 - 18	18	22	6,3	9150	25400	32	3,61	100	80	0,007
UTL 150 - 19	19	24	6,3	12500	36000	49	5,22	140	110	0,007
UTL 150 - 20	20	25	6,3	12000	36000	53	5,33	135	105	0,009
UTL 150 - 22	22	26	6,3	9000	36000	66	6	135	115	0,007
UTL 150 - 24	24	28	6,3	8400	36000	73	6,13	130	110	0,008
UTL 150 - 25	25	30	6,3	10000	36000	72	5,77	115	95	0,009
UTL 150 - 28	28	32	6,3	7500	36000	88	6,33	115	100	0,01
UTL 150 - 30	30	35	6,3	8600	36000	91	6,08	100	85	0,011
UTL 150 - 32	32	36	6,3	7900	45000	131	8,24	130	115	0,011
UTL 150 - 35	35	40	7	10000	54000	171	9,77	125	110	0,016
UTL 150 - 36	36	42	7	11700	54000	169	9,39	115	100	0,019
UTL 150 - 38	38	44	7	11000	54000	181	9,55	110	95	0,021
UTL 150 - 40	40	45	8	13900	66000	231	11,57	115	105	0,021
UTL 150 - 42	42	48	8	15550	66000	235	11,22	110	95	0,026
UTL 150 - 45	45	52	10	28300	99000	353	15,71	105	95	0,045
UTL 150 - 48	48	55	10	24700	132000	572	23,84	155	135	0,045
UTL 150 - 50	50	57	10	23600	132000	602	24,08	150	130	0,045
UTL 150 - 55	55	62	10	21700	132000	670	24,35	140	125	0,049
UTL 150 - 56	56	64	12	29500	157200	790	28,2	130	115	0,07
UTL 150 - 60	60	68	12	27500	157200	860	28,6	125	110	0,07
UTL 150 - 63	63	71	12	26500	157200	910	28,8	120	105	0,08
UTL 150 - 65	65	73	12	25500	157200	950	29,2	115	100	0,09
UTL 150 - 70	70	79	14	31000	209600	1380	39,4	125	110	0,115
UTL 150 - 71	71	80	14	31000	209600	1400	39,4	120	110	0,11
UTL 150 - 75	75	84	14	34700	209600	1450	38,6	115	100	0,12
UTL 150 - 80	80	91	17	48000	290000	2200	55	125	105	0,21
UTL 150 - 85	85	96	17	45500	305000	2400	56,4	120	105	0,21
UTL 150 - 90	90	101	17	43600	320000	2730	60,5	120	105	0,22
UTL 150 - 95	95	106	17	41300	330000	3050	64,2	120	110	0,23
UTL 150 - 100	100	114	21	61000	445000	4200	84	120	105	0,39

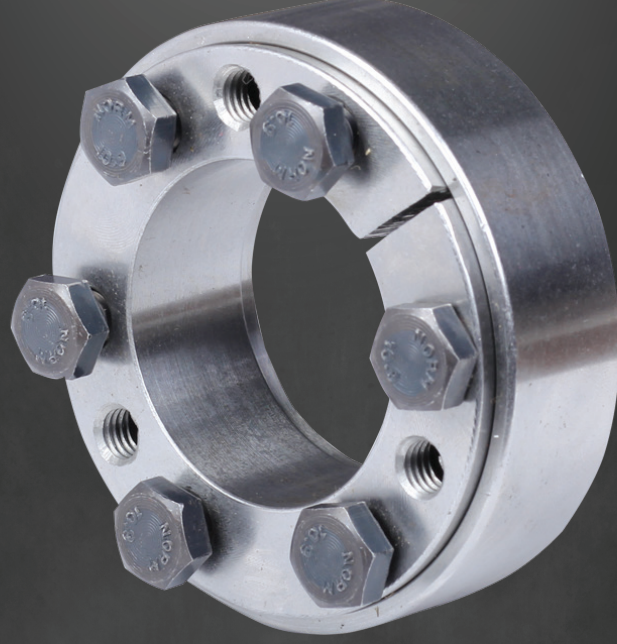

UTL - 550



ŞİRİNK DİSK

UTL - 550 ; iki konik parça ve DIN 931 normlarına uygun bağlantı elemanlarından oluşmaktadır.

Orta ve yüksek tork gerektiren yerlerde uygulanması önerilir.

h8 Tolerans - $Rt \leq 16 \mu m$



SHRINK DISCS

UTL - 550 are shrink discs for external, series "550", are characterised by a single tapered ring instead of opposite tapers of the 3 pieces shrink discs UTL series "600-601-602". The UTL - 550 Shrink discs offer a better concentricity and centering and very good balancing. These features make the series highly suitable for mid-high speed applications.

h8 Tolerance - $Rt \leq 16 \mu m$

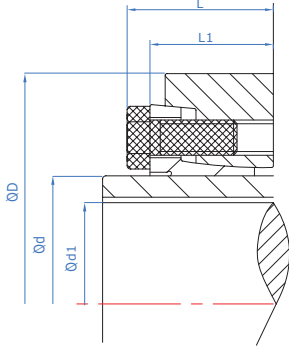

UTL - 550 Teknik Özellikler / Technical Properties

Ma	Vida sıkma döndürme momenti / Screw tightening torque
Mt	Maksimum aktarılabilen döndürme momenti (Fass=0 kN) / Transmissible torque moment
Fass	Maksimum aktarılabilen aksel yük (Mt=0 Nm) / Transmissible axial load
Ps	Kovan miline temas basıncı / Hollow shaft pressure

Sipariş Kodu / Code	Ölçüler / Dimensions					Bağlantı elemanları / Tightening screws		Başarımlar / Performances			Ağırlık / Weight kg
	d1	d	D	L1	L	DIN 931		Ma	Mt	Fass	
	mm	mm	mm	mm	mm	Ad.	10.9 TİP	Nm	Nm	kN	
UTL 550 - 24	19	24	50	18	22	4	M6	12	160	17	0,2
	20								210	20	
	22								280	25	
UTL 550 - 30	24	30	60	20	24	6	M6	12	270	23	0,3
	25								320	25	
	26								360	28	
UTL 550 - 36	27	36	72	22	27,5	5	M8	30	440	32	0,5
	30								610	41	
	33								820	50	
UTL 550 - 44	34	44	80	24	29,5	5	M8	30	690	41	0,6
	35								770	44	
	37								920	50	
UTL 550 - 50	38	50	90	26	31,5	7	M8	30	1.110	58	0,8
	40								1.290	65	
	42								1.510	71	
UTL 550 - 55	42	55	100	29	34,5	8	M8	30	1.230	59	1,1
	45								1.530	68	
	48								1.860	78	
UTL 550 - 62	48	62	110	29	34,5	8	M8	30	1.670	70	1,3
	50								1.890	76	
	52								2.120	81	
UTL 550 - 68	50	68	115	29	34,5	9	M8	30	1.870	75	1,3
	55								2.450	89	
	60								3.120	104	
UTL 550 - 75	55	75	138	31	38	8	M10	59	2.330	85	2,3
	60								3.020	101	
	65								3.810	117	
UTL 550 - 80	60	80	141	31	38	8	M10	59	3.190	106	2,3
	65								4.060	123	
	70								4.910	140	
UTL 550 - 90	65	90	155	38	45	10	M10	59	5.400	166	3,2
	70								6.500	187	
	75								7.800	208	
UTL 550 - 100	70	100	170	43	50	12	M10	59	6.000	171	4,3
	75								7.200	192	
	80								8.500	213	
UTL 550 - 110	80	110	185	49	57	10	M12	100	10.000	249	5,8
	85								11.700	275	
	90								13.600	302	
UTL 550 - 120	85	120	197	53	61	12	M12	100	11.900	280	6,9
	90								13.800	307	
	95								15.900	334	

Daha büyük çaplı UTL Konik Kilit ihtiyaçlarınız için bizi arayınız. / For assemblies requiring larger dimensions, contact our technical department.



UTL - 600



ŞİRİNK DİSK

UTL - 600-601-602 ; iki konik yanak, bir iç çember ve DIN 931 normlarına uygun bağlantı elemanlarından oluşmaktadır.

Düşük tork gerektiren yerlerde (UTL 600) , yüksek tork gerektiren yerlerde (UTL 601), orta ve yüksek tork gerektiren yerlerde (UTL 602) uygulanması önerilir.

h8 Tolerans - $R_t \leq 16 \mu\text{m}$



SHRINK DISCS

UTL - 600-601-602 are external locking devices which are installed over hub projections. By locking the screws, radial pressures act on the hub allowing an effective and solid connection. Recommended for low, medium and high torque.

h8 Tolerance - $R_t \leq 16 \mu\text{m}$

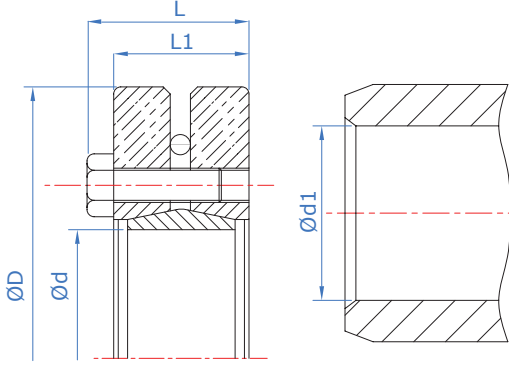

UTL - 600 Teknik Özellikler / Technical Properties

Ma	Vida sıkma döndürme momenti / Screw tightening torque
Mt	Maksimum aktarılabilen döndürme momenti (Fass=0 kN) / Transmissible torque moment
Fass	Maksimum aktarılabilen aksel yük (Mt=0 Nm) / Transmissible axial load
Ps	Kovan miline temas basıncı / Hollow shaft pressure

Sipariş Kodu / Code	Ölçüler / Dimensions					Bağlantı elemanları / Tightening screws		Başarımlar / Performances				Ağırlık / Weight kg		
	d1	d	D	L1	L	DIN 931		Ma	Mt	Fass	Ps			
	mm	mm	mm	mm	mm	Ad.	10.9 TİP	Nm	Nm	kN	N/mm²			
UTL 600 - 24	19	24	50	18	22	6	M5	4	200	21	151	0,20		
	20								250				25	176
	21								310				30	202
UTL 600 - 30	24	30	60	20	24	7	M5	4	310	26	127	0,30		
	25								370				30	144
	26								440				34	160
UTL 600 - 36	28	36	72	22	26	5	M6	12	720	51	188	0,40		
	30								910				61	214
	31								940				60	210
UTL 600 - 44	34	44	80	24	28	7	M6	12	1 160	68	180	0,60		
	35								1 290				73	192
	36								1 420				79	204
UTL 600 - 50	38	50	90	26	30	8	M6	12	1 440	75	161	0,80		
	40								1 730				86	179
	42								2 050				97	199
UTL 600 - 55	42	55	100	29	33	8	M6	12	1 580	75	137	1,10		
	45								2 030				90	160
	48								2 550				100	184
UTL 600 - 62	48	62	110	29	33	10	M6	12	2 550	100	167	1,30		
	50								2 910				110	181
	52								3 090				110	182
UTL 600 - 68	50	68	115	29	33	10	M6	12	2 350	90	135	1,4		
	55								2 970				100	151
	60								4 060				130	185
UTL 600 - 75	55	75	138	31	36,5	7	M8	30	3 370	120	147	1,7		
	60								4 540				150	176
	65								5 880				180	206
UTL 600 - 80	60	80	145	31	36,5	7	M8	30	3 890	120	142	1,9		
	65								5 100				150	168
	70								6 470				180	196
UTL 600 - 85	60	85	155	38	43,5	10	M8	30	5 180	170	156	3,5		
	65								6 690				200	180
	70								8 400				240	205
UTL 600 - 90	65	90	155	38	43,5	10	M8	30	5 910	180	152	3,3		
	70								7 470				210	174
	75								9 200				240	196
UTL 600 - 95	65	95	170	43	48,5	12	M8	30	6 400	190	144	3,8		
	70								8 100				230	164
	75								10 000				260	184
UTL 600 - 100	70	100	170	43	48,5	12	M8	30	7 300	200	141	4,7		
	75								9 000				240	158
	80								11 000				270	177

Daha büyük çaplı UTL Konik Kilit ihtiyaçlarınız için bizi arayınız. / For assemblies requiring larger dimensions, contact our technical department.



UTL - 601



ŞİRİNK DİSK

UTL - 600-601-602 ; iki konik yanak, bir iç çember ve DIN 931 normlarına uygun bağlantı elemanlarından oluşmaktadır.

Düşük tork gerektiren yerlerde (UTL 600) , yüksek tork gerektiren yerlerde (UTL 601), orta ve yüksek tork gerektiren yerlerde (UTL 602) uygulanması önerilir.

h8 Tolerans - $Rt \leq 16 \mu m$



SHRINK DISCS

UTL - 600-601-602 are external locking devices which are installed over hub projections. By locking the screws, radial pressures act on the hub allowing an effective and solid connection. Recommended for low, medium and high torque.

h8 Tolerance - $Rt \leq 16 \mu m$

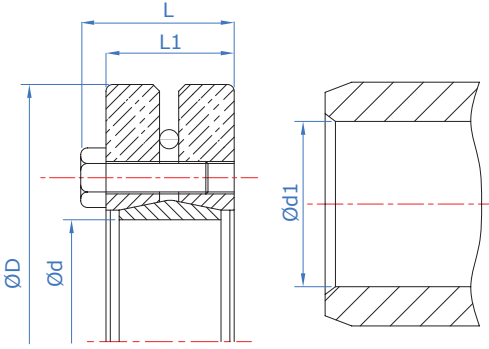

UTL - 601 Teknik Özellikler / Technical Properties

Ma	Vida sıkma döndürme momenti / Screw tightening torque
Mt	Maksimum aktarılabilen döndürme momenti (Fass=0 kN) / Transmissible torque moment
Fass	Maksimum aktarılabilen aksel yük (Mt=0 Nm) / Transmissible axial load
Ps	Kovan miline temas basıncı / Hollow shaft pressure

Sipariş Kodu / Code	Ölçüler / Dimensions					Bağlantı elemanları / Tightening screws		Başarımlar / Performances				Ağırlık / Weight kg
	d1	d	D	L1	L	DIN 931		Ma	Mt	Fass	Ps	
	mm	mm	mm	mm	mm	Ad.	10.9 TİP	Nm	Nm	kN	N/mm ²	
UTL 601 - 125	85	125	215	66	74	12	M12	100	18.700	442	161	11
	90								22.500	500	177	
	95								26.600	560	193	
UTL 601 - 140	95	140	230	74	82	12	M12	100	19.800	417	122	13
	100								23.500	472	134	
	105								27.600	527	146	
UTL 601 - 155	105	155	263	80	88	15	M12	100	29.000	553	133	20
	110								33.600	612	143	
	115								38.500	671	154	
UTL 601 - 165	115	165	290	88	98	10	M16	250	45.800	800	163	26
	120								51.900	870	173	
	125								58.300	930	183	
UTL 601 - 175	125	175	300	88	98	10	M16	250	52.200	840	157	29
	130								58.500	900	166	
	135								65.100	970	175	
UTL 601 - 185	135	185	330	112	122	15	M16	250	89.400	1330	189	47
	140								99.000	1410	198	
	145								109.100	1510	207	
UTL 601 - 200	145	200	350	112	122	15	M16	250	94.900	1310	171	50
	150								104.400	1390	179	
	155								114.300	1480	186	
UTL 601 - 220	160	220	370	134	144	20	M16	250	142.900	1790	175	65
	165								155.500	1890	181	
	170								168.600	1980	187	
UTL 601 - 240	170	240	405	144	159	15	M20	490	174.500	2050	176	87
	180								203.100	2260	188	
	190								234.100	2460	199	
UTL 601 - 260	190	260	430	160	175	18	M20	490	244.600	2580	178	100
	200								280.500	2810	189	
	210								319.000	3040	199	
UTL 601 - 280	210	280	460	172	187	20	M20	490	315.000	3000	175	132
	220								356.100	3240	184	
	230								400.000	3480	193	
UTL 601 - 300	230	300	485	176	191	20	M20	490	356.100	3100	161	140
	240								395.600	3320	169	
	250								420.800	3440	173	



UTL - 602



ŞİRİNK DİSK

UTL - 600-601-602 ; iki konik yanak, bir iç çember ve DIN 931 normlarına uygun bağlantı elemanlarından oluşmaktadır.

Düşük tork gerektiren yerlerde (UTL 600) , yüksek tork gerektiren yerlerde (UTL 601), orta ve yüksek tork gerektiren yerlerde (UTL 602) uygulanması önerilir.

h8 Tolerans - $R_t \leq 16 \mu m$



SHRINK DISCS

UTL - 600-601-602 are external locking devices which are installed over hub projections. By locking the screws, radial pressures act on the hub allowing an effective and solid connection. Recommended for low, medium and high torque.

h8 Tolerance - $R_t \leq 16 \mu m$

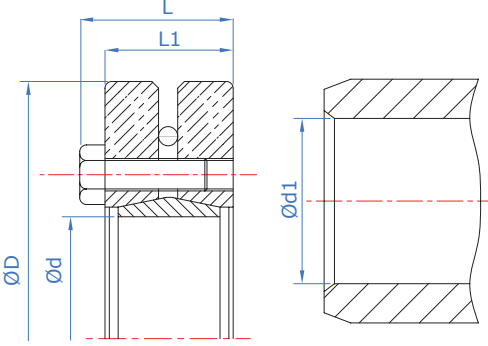

UTL - 602 Teknik Özellikler / Technical Properties

Ma	Vida sıkma döndürme momenti / Screw tightening torque
Mt	Maksimum aktarılabilen döndürme momenti (Fass=0 kN) / Transmissible torque moment
Fass	Maksimum aktarılabilen aksel yük (Mt=0 Nm) / Transmissible axial load
Ps	Kovan miline temas basıncı / Hollow shaft pressure

Sipariş Kodu / Code	Ölçüler / Dimensions					Bağlantı elemanları / Tightening screws		Başarımlar / Performances				Ağırlık / Weight kg
	d1	d	D	L1	L	DIN 931		Ma	Mt	Fass	Ps	
	mm	mm	mm	mm	mm	Ad.	10.9 TIP	Nm	Nm	kN	N/mm ²	
UTL 602 - 125	85	125	190	52	59	8	M10	59	10.600	225	99	6
	90								12.800	258	111	
	95								15.300	292	125	
UTL 602 - 140	95	140	220	52	59	10	M10	59	18.200	331	126	8
	100								23.900	399	149	
	105								26.700	428	160	
UTL 602 - 155	105	155	245	52	59	12	M10	59	30.100	464	154	10
	110								33.700	500	166	
	115								37.600	537	179	
UTL 602 - 165	115	165	260	62	70	10	M12	100	36.300	539	149	14
	120								40.500	579	159	
	125								44.800	619	170	
UTL 602 - 175	125	175	275	62	70	10	M12	100	40.000	552	142	16
	130								44.200	590	152	
	135								48.700	629	162	
UTL 602 - 185	135	185	295	62	70	12	M12	100	53.900	697	168	20
	140								58.900	737	177	
	145								64.100	777	188	
UTL 602 - 195	145	195	315	72	80	15	M12	100	73.300	889	171	27
	150								79.500	936	180	
	155								86.100	984	189	
UTL 602 - 220	160	220	345	84	94	10	M16	250	99.800	1.109	185	35
	165								111.800	1.177	171	
	170								128.600	1.287	186	
UTL 602 - 240	170	240	370	84	94	12	M16	250	135.700	1.357	179	44
	180								154.200	1.469	193	
	190								164.000	1.526	201	
UTL 602 - 260	190	260	395	92	102	12	M16	250	153.000	1.392	167	48
	200								170.400	1.482	161	
	210								180.500	1.536	167	
UTL 602 - 280	210	280	425	104	114	16	M16	250	207.300	1.803	180	60
	220								228.300	1.903	171	
	230								253.600	2.030	181	
UTL 602 - 300	230	300	460	104	114	18	M16	250	258.900	2.071	172	75
	240								283.700	2.183	181	
	250								312.500	2.315	192	

UTL®

Rijit Kaplinler Rigid Couplings



UTL - 500



RİJİD KAPLİN

UTL - 500 ; iki konik yanak, bir iç çember ve DIN 912 normlarına uygun bağlantı elemanlarından oluşmaktadır.

Orta tork gerektiren yerlerde uygulanması önerilir. Milden mile bağlantı yapmak için tasarlanmıştır. Farklı çaplı millerde de uygulanabilmektedir.

h8 Tolerans - $Rt \leq 16 \mu m$



RIGID COUPLING

UTL - 500 are rigid couplings for shaft to shaft connections.

They offer easy angular timing and axial adjustment of shaft ends. They transmit medium torque and bending moment without keys and offer a low cost solution for shaft to shaft rigid connection. Double diameter versions are available.

h8 Tolerance - $Rt \leq 16 \mu m$

www.utl.com.tr

www.utllockingassemblies.com

UTL - 500 Teknik Özellikler / Technical Properties

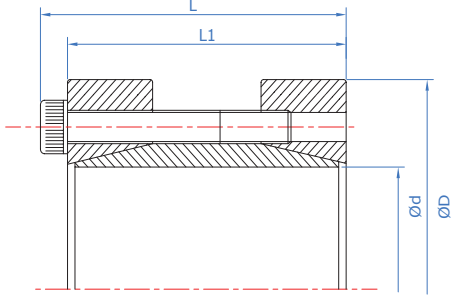

M_A	Vida sıkma döndürme momenti / Screw tightening torque
M_t	Maksimum aktarılabilen döndürme momenti ($F_{ass}=0$ kN) / Transmissible torque moment
F_{ass}	Maksimum aktarılabilen eksenel yük ($M_t=0$ Nm) / Transmissible axial load
P_s	Mile temas basıncı / Shaft pressure

Sipariş Kodu / Code	Ölçüler / Dimensions				Bağlantı elemanları / Tightening screws		Başarımlar / Performances				Ağırlık / Weight kg
	d	D	L1	L	DIN 912		M_A	M_t	F_{ass}	P_s	
	mm	mm	mm	mm	Ad.	12.9 TİP	Nm	Nm	kN	N/mm ²	
UTL 500 - 15	15	50	50	56	4	M6	17	140	19	285	0,4
UTL 500 - 16	16	50	50	56	4	M6	17	160	20	267	0,4
UTL 500 - 17	17	50	50	56	4	M6	17	180	21	251	0,5
UTL 500 - 18	18	50	50	56	4	M6	17	180	20	237	0,5
UTL 500 - 19	19	50	50	56	4	M6	17	200	21	225	0,5
UTL 500 - 20	20	50	50	56	4	M6	17	220	22	213	0,5
UTL 500 - 22	22	50	60	66	6	M6	17	320	29	247	0,6
UTL 500 - 24	24	55	60	66	6	M6	17	390	32	227	0,6
UTL 500 - 25	25	55	60	66	6	M6	17	420	33	218	0,6
UTL 500 - 28	28	60	60	66	6	M6	17	440	31	194	0,7
UTL 500 - 30	30	60	60	66	6	M6	17	500	34	181	0,7
UTL 500 - 32	32	65	60	66	6	M6	17	540	34	170	1,3
UTL 500 - 35	35	75	75	83	4	M8	41	570	32	146	1,3
UTL 500 - 38	38	75	75	83	4	M8	41	670	35	134	1,3
UTL 500 - 40	40	75	75	83	4	M8	41	740	37	128	1,3
UTL 500 - 42	42	78	75	83	4	M8	41	780	37	121	2,8
UTL 500 - 45	45	85	85	93	6	M8	41	1 260	56	150	2,5
UTL 500 - 48	48	90	85	93	6	M8	41	1 310	55	141	2,4
UTL 500 - 50	50	90	85	93	6	M8	41	1 420	57	135	2,3
UTL 500 - 55	55	95	85	93	8	M8	41	2 110	77	164	3,3
UTL 500 - 60	60	100	85	93	8	M8	41	2 330	78	150	3,2
UTL 500 - 65	65	105	85	93	8	M8	41	2 550	78	139	3
UTL 500 - 70	70	115	100	110	6	M10	83	3 370	96	138	5,4
UTL 500 - 75	75	120	100	110	6	M10	83	3 640	97	128	5
UTL 500 - 80	80	125	100	110	8	M10	83	5 220	130	161	4,7
UTL 500 - 85	85	130	100	110	8	M10	83	5 570	131	151	5,9
UTL 500 - 90	90	135	100	110	8	M10	83	5 930	132	143	6



UTL - 501



RİJİD KAPLIN

UTL - 501 ; iki konik yanak, bir iç çember ve DIN 931 normlarına uygun bağlantı elemanlarından oluşmaktadır.

Yüksek tork gerektiren yerlerde uygulanması önerilir. Milden mile bağlantı yapmak için tasarlanmıştır. Farklı çaplı millerde de uygulanabilmektedir.

h8 Tolerans - $R_t \leq 16 \mu m$



RIGID COUPLING

UTL - 501 are rigid couplings for shaft to shaft connections.

They offer easy angular timing and axial adjustment of shaft ends. They transmit high torque and bending moment without keys and offer a low cost solution for shaft to shaft rigid connection.

Double diameter versions are available.

h8 Tolerance - $R_t \leq 16 \mu m$

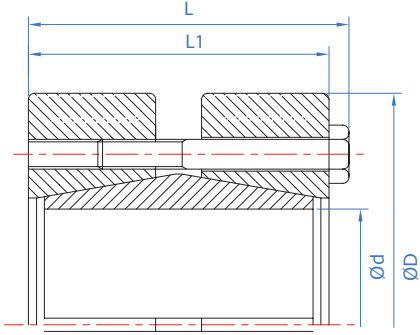

UTL - 501 Teknik Özellikler / Technical Properties

Ma	Vida sıkma döndürme momenti / Screw tightening torque
Mt	Maksimum aktarılabilen döndürme momenti (Fass=0 kN) / Transmissible torque moment
Fass	Maksimum aktarılabilen eksenel yük (Mt=0 Nm) / Transmissible axial load
Ps	Mile temas basıncı / Shaft pressure

Sipariş Kodu / Code	Öçüler / Dimensions				Bağlantı elemanları / Tightening screws		Başarımlar / Performances				Ağırlık / Weight kg
	d	D	L1	L	DIN 931		Ma	Mt	Fass	Ps	
	mm	mm	mm	mm	Ad.	10.9 TİP	Nm	Nm	kN	N/mm ²	
UTL 501-15	15	52	34	38	3	M6	12	160	22	226	0,4
UTL 501-16	16	52	34	38	3	M6	12	170	22	212	0,4
UTL 501-19	19	52	34	34	3	M6	12	205	22	178	0,4
UTL 501-20	20	60	40	44	5	M6	12	360	36	240	0,6
UTL 501-22	22	60	40	44	5	M6	12	400	36	216	0,6
UTL 501-24	24	60	40	44	5	M6	12	435	36	200	0,6
UTL 501-25	25	66	44	48	7	M6	12	630	51	245	0,8
UTL 501-28	28	66	44	48	7	M6	12	710	51	219	0,8
UTL 501-29	29	66	44	48	7	M6	12	735	51	211	0,7
UTL 501-30	30	76	48	52	8	M6	12	870	58	213	1,2
UTL 501-32	32	76	48	52	8	M6	12	925	58	200	1,2
UTL 501-35	35	76	48	52	8	M6	12	1 020	58	183	1,2
UTL 501-36	36	96	56	62	7	M8	30	1 750	97	257	1,2
UTL 501-40	40	96	56	62	7	M8	30	1 950	97	231	2,3
UTL 501-44	44	96	56	62	7	M8	30	2 140	97	210	2,2
UTL 501-50	50	112	68	74	10	M8	30	3 480	139	217	3,6
UTL 501-51	51	112	68	74	10	M8	30	3 550	139	213	3,6
UTL 501-54	54	112	68	74	10	M8	30	3 760	139	201	3,6
UTL 501-55	55	120	78	84	12	M8	30	4 600	167	207	3,6
UTL 501-60	60	120	78	84	12	M8	30	5 010	167	189	4,7
UTL 501-63	63	120	78	84	12	M8	30	5 260	167	180	4,5
UTL 501-65	65	148	88	95	12	M10	60	8 620	265	245	4,4
UTL 501-68	68	148	88	95	12	M10	60	9 040	265	234	4,3
UTL 501-70	70	148	88	95	12	M10	60	9 270	265	228	8,7
UTL 501-73	73	148	88	95	12	M10	60	9 670	265	219	8,4
UTL 501-74	74	170	104	112	10	M12	100	11 650	315	217	8,2
UTL 501-76	76	170	104	112	10	M12	100	11 990	315	211	8,1
UTL 501-80	80	170	104	112	10	M12	100	12 590	315	201	12,8
UTL 501-85	85	170	104	112	10	M12	100	13 380	315	189	12,7
UTL 501-86	86	185	116	124	12	M12	100	16 200	378	201	12,2
UTL 501-90	90	185	116	124	12	M12	100	17 000	378	192	16,5
UTL 501-92	92	185	116	124	12	M12	100	17 400	378	188	17,5
UTL 501-96	96	185	116	124	12	M12	100	18 100	378	180	19,0
UTL 501-100	100	197	126	134	15	M12	100	23 600	472	199	21,0
UTL 501-106	106	197	126	134	15	M12	100	25 000	472	188	23,0
UTL 501-108	108	197	126	134	15	M12	100	25 500	472	184	24,0
UTL 501-110	110	197	126	134	15	M12	100	26 000	472	181	26,0

Standart Seri Konik Kilitler / Standard Series Locking Assemblies



Mini Seri / Mini Series



UTL Plus / UTL Plus



Paslanmaz Konik Kilitler / Locking Assemblies Stainless Steel

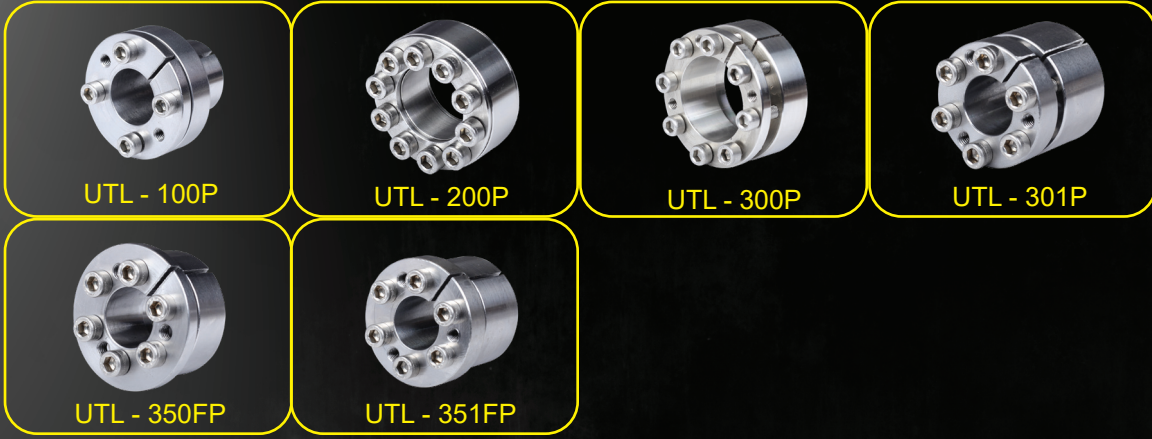

Kilitleme Elemanları / Locking Elements



Şirink Diskler / Shrink Discs



Rijit Kaplinler / Rigid Couplings

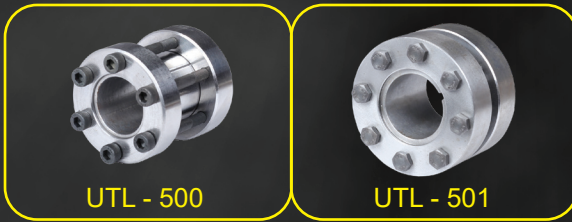

KARŞILAŞTIRMA REHBERİ / INTERCHANGE GUIDE

UTL Karşılaştırma rehberindeki sipariş kodları arasındaki ölçü ve başarımların aynı olmasını garanti etmez.
UTL Does not guarantee exact equivalence; dimensions and capacities may differ.

UTL® Konik Kilit Sistemleri	KTR	Ringspann	Chiaravalli	Ringfeder	Tas Schafer	Mav	Tollok
Standard Seri Konik Kilitler Standard Series Locking Assemblies	Series - UTL 100	Clampex KTR 250	RLK 110	RCK 80	RfN 7110	Tas 110	TLK 110
	Series - UTL 200	Clampex KTR 100	RLK 200	RCK 40	RfN 7012	TAS 3020	TLK 200
	Series - UTL 201	Not available	Not available	Not available	Not available	Not available	Not available
	Series - UTL 300	Clampex KTR 203	RLK 132	RCK 13	RfN 7003	TAS 3003	TLK 132
	Series - UTL 301	Clampex KTR 200	RLK 130	RCK 70	RfN 7004	Tas 130	TLK 130
	Series - UTL 350	Not available	Not available	Not available	Not available	Not available	Not available
	Series - UTL 351	Clampex KTR 201	RLK 131	RCK 71	RfN 7007	Tas 131	Not available
	Series - UTL 350F	Clampex KTR 206	RLK 133	RCK 16	RfN 7006	TAS 3006	TLK 133
	Series - UTL 351F	Not available	Not available	Not available	Not available	Not available	TLK 131
	Series - UTL 400	Not available	RLK 404	Not available	RfN 7515	TAS 3015	TLK 451
	Series - UTL 401	Clampex KTR 400	RLK 402	RCK 11	RfN 7005	TAS 3012	TLK 452
	Series - UTL 600	Clampex KTR 603	RLK 603	RCK 19	RfN 4061	TAS 3071	TLK 603
	Series - UTL 601	Not available	Not available	Not available	RfN 4091	TAS 3091	TLK 602
	Series - UTL 602	Not available	Not available	Not available	RfN 4051	TAS 3051	TLK 601
	Series - UTL 550	Clampex KTR 620	RLK 606	Not available	RfN 4161	TAS 3171	TLK 622
	Series - UTL 500	Clampex KTR 700	RLK 500	RCK 95	Not available	TAS WLB	TLK 500
Series - UTL 501	Not available	Not available	Not available	Not available	Not available	Not available	
Series - UTL 100M	Not available	Not available	Not available	Not available	Not available	Not available	
Series - UTL 201M	Clampex KTR 105	RLK 350	RCK 61	RfN 7061	Not available	TLK 350	
Series - UTL 350FM	Not available	Not available	Not available	Not available	Not available	Not available	
Series - UTL 501M	Not available	Not available	Not available	Not available	Not available	Not available	
Series - UTL 550M	Not available	Not available	Not available	Not available	Not available	Not available	
Series - UTL 150	Clampex KTR 150	RLK 300	RCK 50	RfN 8006	Tas 8006	TLK 300	

Shrink Diskler
Shrink Discs

Rijit Kaplinler
Rigid Couplings

Mini Seri
Mini Series

Kilitleme Elemanları
Locking Elements

UTL® Konik Kilit Sistemleri
Locking Assemblies

Adres: İOSB Tormak San. Sit. H Blok No : 47 34306 Başakşehir - İstanbul / TÜRKİYE
Tel: +90 212 549 62 76
info@utl.com.tr sales.international@utllockingassemblies.com